



Standard Specification for Anodes, Sacrificial Zinc Alloy¹

This standard is issued under the fixed designation F 1182; the number immediately following the designation indicates the year of original adoption or, in the case of revision, the year of last revision. A number in parentheses indicates the year of last reapproval. A superscript epsilon (ϵ) indicates an editorial change since the last revision or reapproval.

1. Scope

1.1 This specification covers the requirements for zinc anodes in the form of slabs, plates, discs, and rods for corrosion protection (cathodic protection) of metals and alloys.

1.2 The anodes are primarily intended to reduce corrosion of surface ship and submarine hulls, steel and aluminum equipment and structures, sea chests, sonar domes, and the seawater side of condensers and other heat exchangers.

1.3 The values stated in inch-pound units are to be regarded as standard. The metric (SI) units, given in parentheses, are for information purposes only and may be approximate.

1.4 *This standard does not purport to address the safety concerns associated with its use. It is the responsibility of the user of this standard to establish appropriate safety and health practices and determine the applicability of regulatory limitations prior to use.*

2. Referenced Documents

2.1 *Order of Precedence*—In the event of a conflict between the text of this specification and the references cited herein, the text of this specification shall take precedence.

2.2 ASTM Standards

A 36/A36M Specification for Carbon Structural Steel²

B 21 Specification for Naval Brass Rod, Bar, and Shapes³

B 103 Specification for Phosphor Bronze Plate, Sheet, Strip, and Rolled Bar³

D 3951 Practice for Commercial Packaging⁴

E 290 Test Method for Semi-Guided Bend Test for Ductility of Metallic Materials⁵

E 536 Test Method for Chemical Analysis of Zinc and Zinc Alloys⁶

2.3 Military Standards:⁷

MIL-STD-105 Sampling Procedures and Tables for Inspection by Attributes

MIL-STD-129 Marking for Shipment and Storage

MIL-STD-1186 Cushioning, Anchoring, Bracing, Blocking, and Waterproofing; With Appropriate Test Methods

2.4 Military Specification:

MIL-P-15011 Pallets Material Handling, Wood Post Construction, 4-Way Entry⁷

2.5 Federal Specifications:⁷

PPP-B-601 Boxes, Wood, Cleated Plywood

PPP-B-621 Boxes, Wood, Nailed and Lock-Corner

PPP-B-636 Boxes, Shipping, Fiberboard

2.6 American National Standards Institute Standard:

ANSI/ASME B1.20.1—Pipe Threads, General Purpose (Inch)⁸

3. Classification

3.1 The anodes shall be of the following classes and types, as specified (see 4.1.2):

3.1.1 Class 1—Cast-in cores:

3.1.1.1 *Type ZHS*—Zinc, hull slab, steel straps, 23 and 42-lb (10 and 19-kg) sizes.

3.1.1.2 *Type ZHB*—Zinc, hull slab, brass straps, 23-lb (10-kg) size.

3.1.1.3 *Type ZHC*—Zinc, hull slab, core strap, 23 and 42-lb (10 and 19-kg) sizes.

3.1.1.4 *Type ZSS*—Zinc, submarine slab, steel strap, 12 and 24-lb (5 and 11-kg) sizes.

3.1.1.5 *Type ZTS*—Zinc, teardrop shape, steel strap, 5-lb (2-kg) size.

3.1.1.6 *Type ZEP*—Zinc, heat exchanger or fair water disc, (pipe core or pipe bushing core):

Style A square slab, 9-lb (4-kg) size

Style B circular slab, various sizes

Style C semicircular slab, 23-lb (10-kg) size

3.1.1.7 *Type ZBP*—Zinc, bar, pipe core, 8-lb (4-kg) size.

3.1.1.8 *Type ZDM*—Zinc, segmented disc, machine formed interlocking core, various sizes.

3.1.2 Class 2—Plain, no cores;

¹ This specification is under the jurisdiction of ASTM Committee F25 on Ships and Marine Technology and is the direct responsibility of Subcommittee F25.07 on General Requirements.

Current edition approved June 29, 1990. Published August 1990. Originally published as F 1182 - 88. Last previous edition F 1182 - 88.

² *Annual Book of ASTM Standards*, Vol 01.04.

³ *Annual Book of ASTM Standards*, Vol 02.01.

⁴ *Annual Book of ASTM Standards*, Vol 15.09.

⁵ *Annual Book of ASTM Standards*, Vol 03.01.

⁶ *Annual Book of ASTM Standards*, Vol 03.05.

⁷ Available from Standardization Documents, Order Desk, Building 4, Section D, 700 Robbins Ave., Philadelphia, PA 19111-5094, Attn: NPODS.

⁸ Available from American National Standards Institute, 25 W. 43rd St., 4th Floor, New York, NY 10036.

3.1.2.1 *Type ZRN*—Zinc, rod, no core, extruded, drawn or rolled.

3.1.2.2 *Type ZPN*—Zinc, plate, no core, rolled.

3.2 The letter designations of types of anodes have the following meanings:

3.2.1 The first letter designates anode metal:

Z zinc

3.2.2 The second letter designates the shape or general use:

H hull slab
 S submarine slab
 T teardrop shape
 E heat exchanger slab
 R rod, cylindrical
 P plate
 B bar, square
 D disc, segmented

3.2.3 The third letter designates the core:

B brass straps
 S steel straps
 C core strap
 P pipe core
 M machine formed interlocking core
 N no core

4. Ordering Information

4.1 Orders for material under this specification shall include the following information:

4.1.1 ASTM designation and year of issue,

4.1.2 Class and type (see 3.1),

4.1.3 Style of Type ZEP, if required (see 3.1.1.6 and Fig. 1),

4.1.4 Diameter of Type ZEP, Style B, if required (see Fig. 1),

4.1.5 For Type ZDM, whether straight or tapered thread support plug head is required (see section 5.1.4.2,)

4.1.6 Diameter of Type ZDM, if required (see Fig. 2),

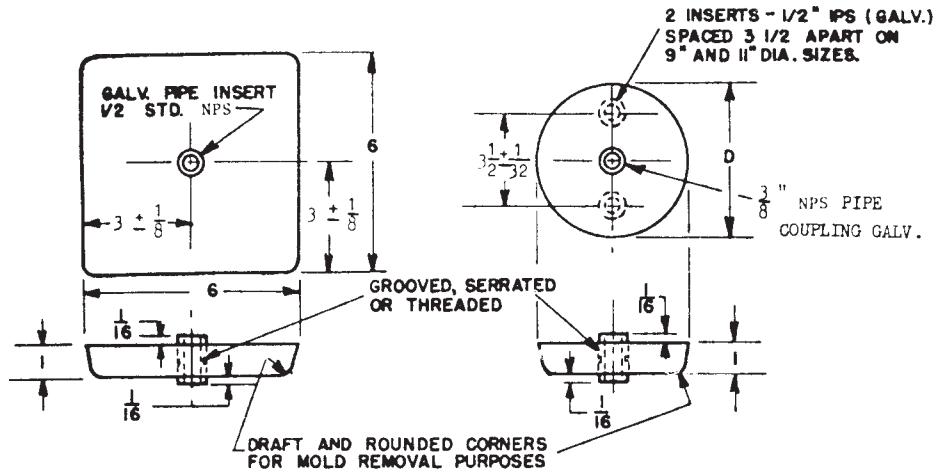

Style A—Square Slab

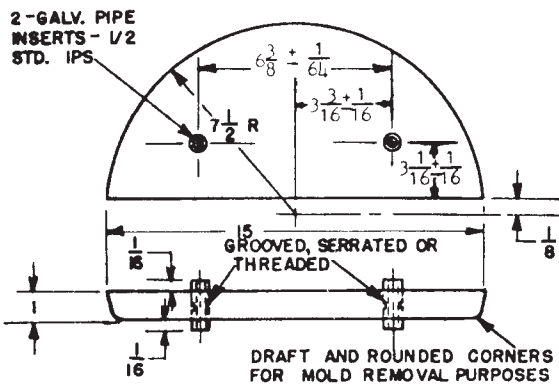

Style C—Semicircular Slab

NOTE—Tolerance for center $\pm 1/8$ in.

Diameter, D, in., $\pm 1/8$ in.	Approximate Weight, lb	Surface Area, in. ²
11	24	130
9	16	92
6	7.1	47
5	4.9	36
4	3.19	26
3	1.78	16
2	0.79	9

Style B—Circular Slab

NOTE 1—1 in. = 25.4 mm.

NOTE 2—1 lb. = 0.45 kg.

NOTE 3—Approximate weight for Style A is 9 lb; approximate weight for Style C is 23 lb.

NOTE 4—All dimensions are in inches.

FIG. 1 ZEP Heat Exchanger Slab

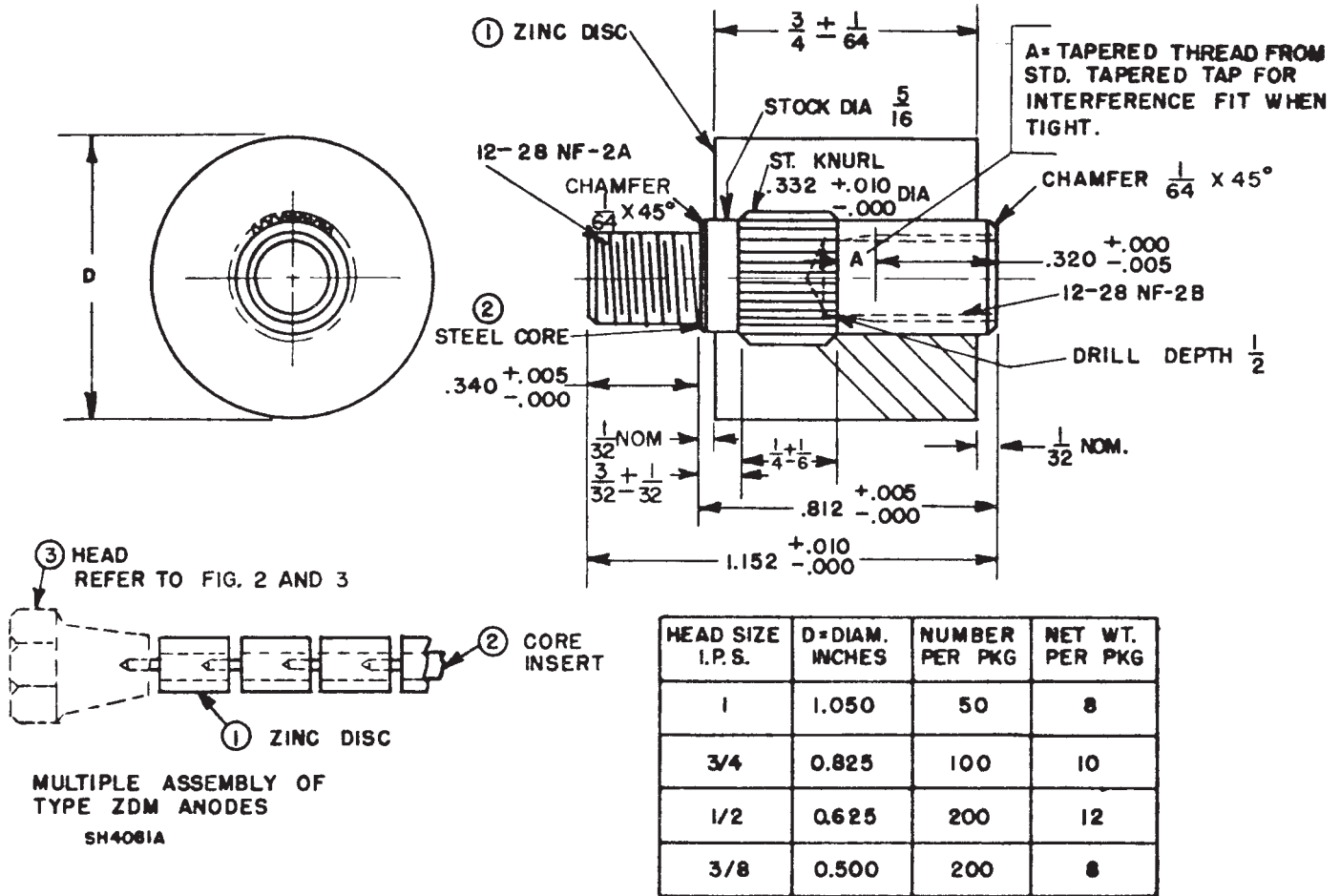

NOTE 1—All dimensions are in inches.
NOTE 2—1 in. = 25.4 mm.

FIG. 2 Zinc, Segmented Disc, Machine-Formed Interlocking Core, Type ZDM

- 4.1.7 Length, width, and thickness of Type ZHS, if required (see Fig. 3 and Fig. 4),
 - 4.1.8 Whether Type ZHC is for surface ship or submarine usage, if required (see Figs. 5-8),
 - 4.1.9 Pipe or bolt diameter of Type ZRN, if required (see Fig. 9),
 - 4.1.10 Thickness of Type ZPN, if required (see 9.2.1),
 - 4.1.11 Quantity required (see 4.2),
 - 4.1.12 Quality assurance certification, if required (see 15.1), and
 - 4.1.13 Optional requirements, if any (see S1 through S3).
- 4.2 The order for anodes should specify the exact number of anodes required (see 4.1.11). Acquisition of anodes by weight is not practical and is not recommended.
- 4.3 When material is ordered in the form of slabs, bars, discs, or rods, these terms refer merely to the general form and dimensions of the material and do not have any technical significance as to the methods of manufacture.

5. Materials and Manufacture

5.1 Materials:

5.1.1 Types ZHS, ZHC, ZSS, and ZTS anodes shall have steel strap cores in accordance with Specification A 36/A36M.

The steel shall be coated with zinc, either by the hot-dip or electrodeposition method, to a minimum of 0.0005 in. (0.013 mm).

5.1.2 Type ZHB anodes shall have brass strap cores in accordance with alloy 482 of Specification B 21 or phosphor bronze straps in accordance with C51000 of Specification B 103. The brass or bronze straps shall be coated with zinc to a minimum thickness of 0.0005 in. (0.013 mm). Lack of adhesion of the zinc coating at bend or absence of zinc coating at cut edges will not be cause for rejection of fabricated anodes. Cracks in the base metal shall be cause for rejection.

5.1.2.1 The maximum copper content in the zinc, as specified in Table 1, may be increased to 0.020 % for Type ZHB anodes.

5.1.3 Types ZEP and ZBP anodes shall have core inserts made from zinc coated steel pipe or pipe couplings. The minimum thickness of the coating shall be as specified in 5.1.1.

5.1.4 Type ZDM anodes shall have machine formed interlocking cores in accordance with commercial grade mild or leaded steel. The cores shall be flash coated with zinc, tin, or aluminum before assembly within the anodes.

5.1.4.1 This core insert consists of an integral piece having a threaded male stud at one end and a tapped hole at the other

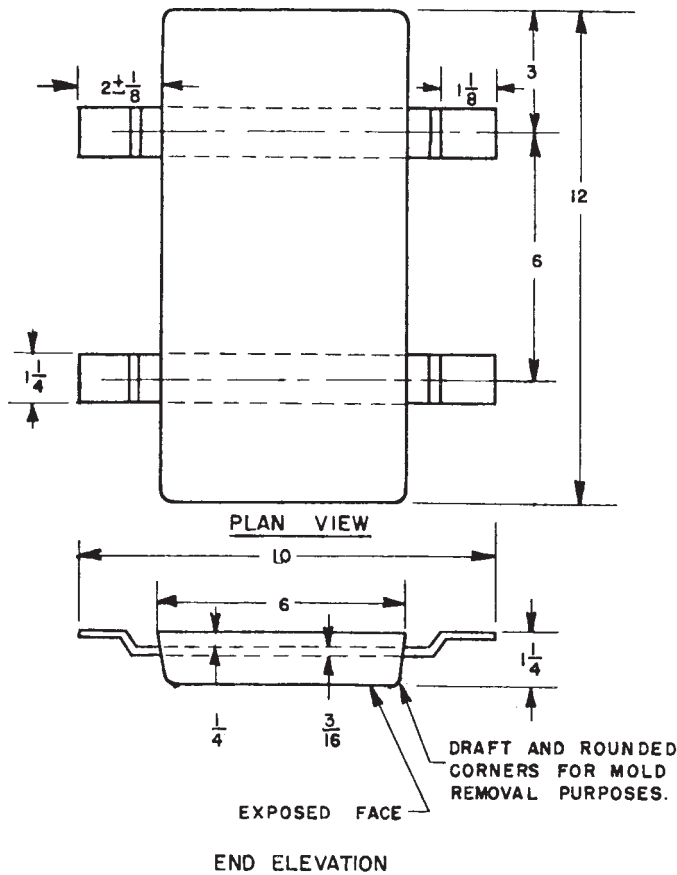

NOTE 1—Anode may be cast with strap in the up or down position. All dimensions (inches) refer to the wider and longer edges of the anodes.
 NOTE 2—Tolerance $\pm 1/8$ in.
 NOTE 3—1 in. = 25.4 mm.
 NOTE 4—Minimum weight 21.5 lb (9.7 kg).

FIG. 3 Zinc Hull Slab (Steel Straps), Type ZHS-23; Zinc Hull Slab (Brass Straps), Type ZHB

end. Provision has been made to achieve self-locking characteristics to interlocking threaded assemblies of multiple segmented anode discs by interference fit of bottom male threads into a taper tapped hole.

5.2 Manufacture:

5.2.1 All anodes covered under this specification shall be manufactured by any process suitable to the contracting agency provided they meet the mechanical properties and other requirements of this specification.

5.2.2 For Types ZHS, ZHB, ZHC, ZSS, and ZTS anodes, open or closed molds may be used. Cores and straps shall be positioned so that they are embedded $1/4$, $+ 1/8$, or $-1/16$ in. (6, +3, or -2 mm) as shown on Figs. 3-5, Fig. 7, and Fig. 10 and Fig. 11, which may be measured from either surface of the anode as applicable, except Fig. 11 (bottom), which shall be embedded $3/8$, $+1/8$, or $-1/16$ in. (10, +3, or -2 mm).

5.2.2.1 Type ZHC anodes designated as shown on Fig. 6 and Fig. 8 and are intended for use with rubber washers for submarine application. The countersink for the rubber washer may be cast or machined. The anode shall be manufactured so that the countersink is centered on the core hole and the rubber

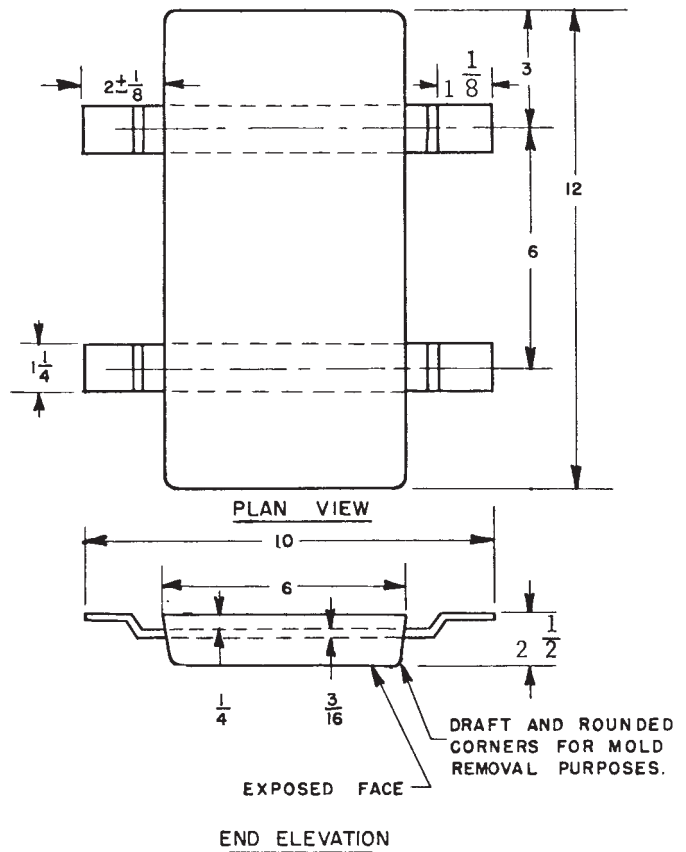

NOTE 1—Anode may be cast with strap in the up or down position. All dimensions (inches) refer to the wider and longer edges of the anode.
 NOTE 2—Tolerance $\pm 1/8$ in.
 NOTE 3—1 in. = 25.4 mm.
 NOTE 4—Minimum weight 41 lb (18.6 kg).

FIG. 4 Zinc Hull Slab (Steel Straps), Type ZHS-42

washer fits snugly between the hull and anode core to prevent anode movement or vibration.

5.2.2.2 Type ZSS, ZHS, ZHB, and ZTS anodes may be mounted by welding or by fasteners. Those intended to be attached by fasteners shall indicate the requirements for mounting holes in the strap. The mounting hole shall be counterbored on the structure side of the strap.

5.2.3 The pipe core inserts for Type ZEP anodes shall conform to 5.1.3. The position of the pipe core insert shall not vary more than $\pm 1/8$ in. (3 mm) from the center as shown on Fig. 1.

5.2.4 The position of the pipe core insert for Type ZBP anodes specified in 5.1.3 shall not vary more than $\pm 1/4$ in. (6 mm) from the center as shown on Fig. 12.

5.2.5 Metallic bonding or an interference fit of the core into Type ZDM anode (see Fig. 2) shall be required so that an axial force applied from the stud end to remove the core insert is a minimum of 750 lb (340 kg) (see 13.1.3).

5.2.6 The machine formed core insert specified in 5.1.4 shall be manufactured in accordance with details and tolerances shown for Piece 2 on Fig. 1 and ANSI/ASME B1.20.1.

5.2.6.1 The pieces shown on Fig. 1 shall screw together very snugly by hand tightening or by using simple hand tools such as pliers or pipe wrenches.

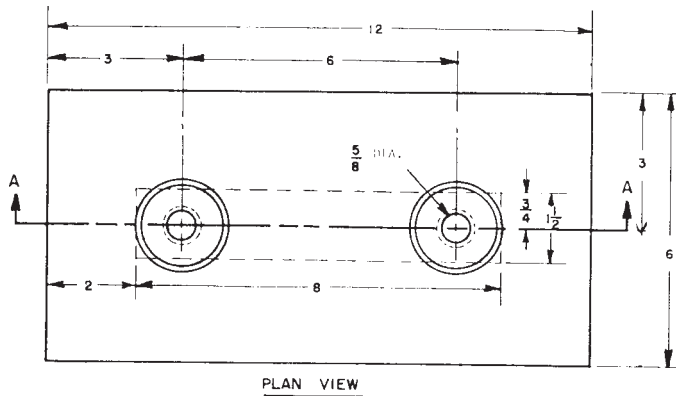

PLAN VIEW

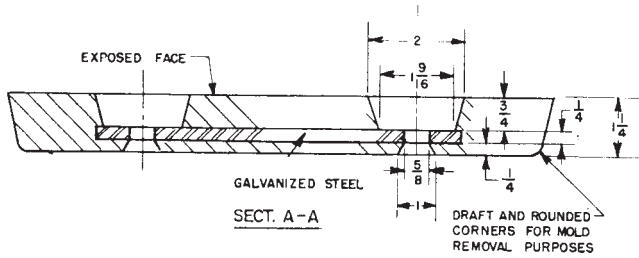

SECT. A-A

NOTE 1—Anode may be cast with exposed face in the up or down position. All dimensions are in inches.

NOTE 2—Tolerance $\pm 1/8$ in.

NOTE 3—1 in. = 25.4 mm.

NOTE 4—Minimum weight 21.5 lb (9.7 kg).

FIG. 5 Zinc Hull Slab (Core Strap), Type ZHC-23

6. Chemical Composition

6.1 The anodes shall conform to the composition specified in Table 1. Total of elemental constituents not specified in Table 1 shall not exceed 0.10 %. Metallic elements not specified in Table 1 are considered contaminants.

7. Mechanical Properties

7.1 When tested in accordance with 13.2, Types ZRN rods and ZPN plates shall not fracture or show signs of cracking.

7.2 When tested in accordance with 13.2.1, ZRN anodes shall have a minimum torsional shear strength of 12 000 psi (83 MPa).

8. Other Requirements

8.1 When tested in accordance with 13.1.1 or 13.1.2, Types ZHS, ZHB, ZHC, ZSS, ZTS, ZEP, and ZBP anodes shall obtain a sound metallurgical bond between the zinc and core for at least 30 % of the total surface area of each core in contact with the anode.

8.2 During the manufacturing process, certain toxic compounds (such as zinc phosphide) may become by-products. Caution should be taken in disposal of process wastewater to ensure that the composition of the water meets with local, state, and federal regulations.

9. Dimensions, Mass, and Permissible Variations

9.1 Types ZHS, ZHB, ZHC, ZTS, ZSS, ZEP, ZBP, ZDM, and ZRN anodes shall be in accordance with the dimensions shown in Figs. 1-11, inclusive.

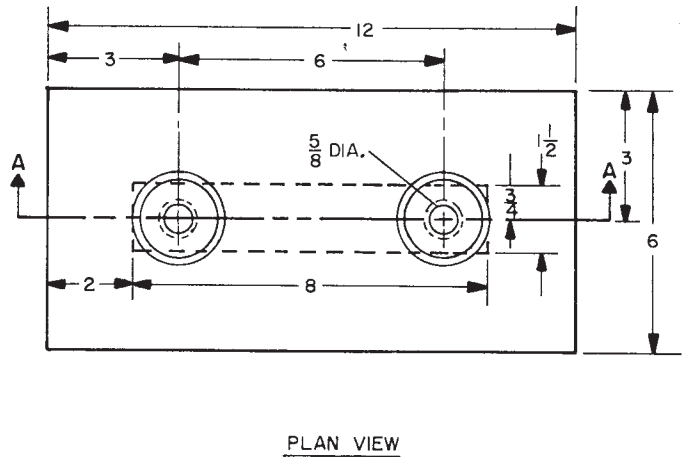

PLAN VIEW

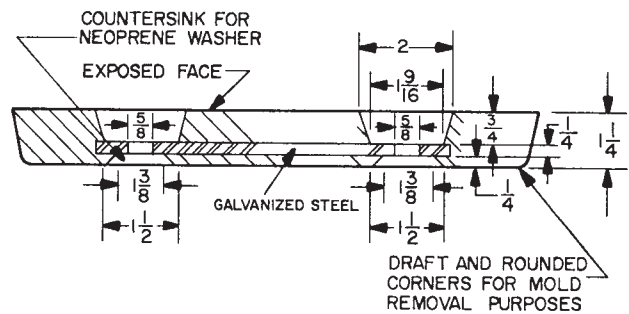

SECTION A-A

NOTE 1—Anode may be cast with exposed face in the up or down position. All dimensions are in inches.

NOTE 2—Tolerance $\pm 1/8$ in.

NOTE 3—1 in. = 25.4 mm.

NOTE 4—Minimum weight 21.5 lb (9.7 kg).

FIG. 6 Zinc Hull Slab (Core Strap), Type ZHC-23, Submarine Application

9.2 Type ZPN anode shall be 48 in. (1220 mm) in length by 24 in. (610 cm) in width.

9.2.1 The thickness shall be either 1/2 or 1 in. (13 or 25 mm) as specified (see 4.1.10).

9.3 Types ZSS-12, ZSS-24, ZHC-23, ZHC-42, ZHS-23, and ZHS-42 shall have the following minimum weight requirements:

Anode	Weight, min, lb (kg)
ZSS-12	11.0 (5)
ZSS-24, ZHC-23, ZHS-23	21.5 (10)
ZHC-42	39.0 (18)
ZHS-42	41.0 (19)

9.3.1 The total weight of the specified type of anode received divided by the total number of anodes of that type shall be equal to or greater than the minimum weight (11.0, 21.5, 39.0, 41.0 lb (5, 10, 18, 19 kg)) of the anode type specified. If the weight is less than the minimum weight for the type of anode specified, it shall be cause for rejection of the entire lot.

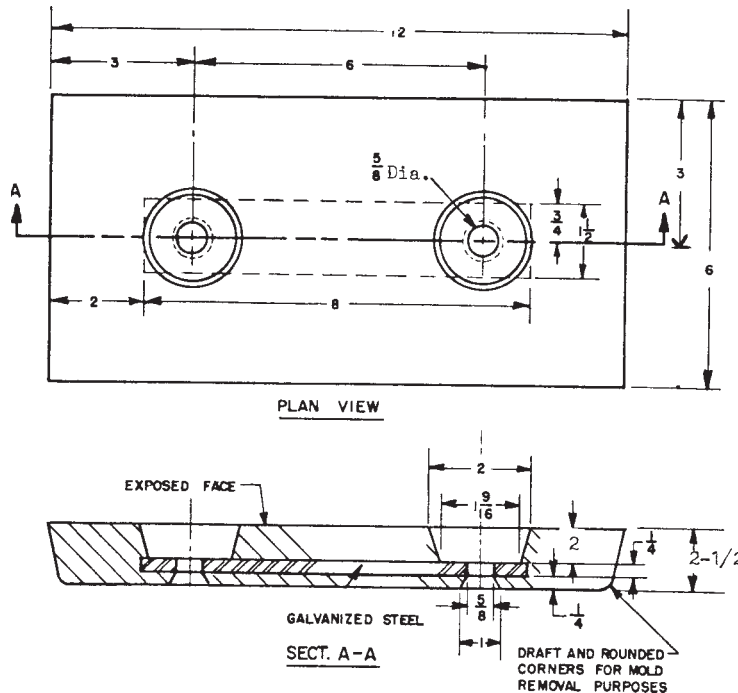

- NOTE 1—Anode may be cast with exposed face in the up or down position. All dimensions are in inches.
 NOTE 2—Tolerance $\pm 1/8$ in.
 NOTE 3—1 in. = 25.4 mm.
 NOTE 4—Minimum weight 39 lb (17.7 kg).

FIG. 7 Zinc Hull Slab (Core Strap), Type ZHC-42

9.4 The length and width of Types ZHS, ZHB, ZHC, ZTS, ZPN, ZSS, and ZBP anodes shall not vary more than $\pm 1/8$ in. (3 mm), measured at the widest surface of the tapered (for mold release) anode.

9.5 The length of Type ZRN anodes will be permitted to have a variation of ± 1 in. (25 mm) based on nominal lengths of 3 and 6 ft (914 and 1829 mm).

9.6 The diameter or width, whichever is the larger, of Type ZEP anodes shall not vary from the specified dimension by more than $\pm 1/8$ in. (3 mm).

9.7 The diameter of Type ZDM anodes shall not vary more than +0.025 in. (1 mm) or -0.005 in. (0.13 mm) from the specified diameter.

9.8 The diameter of the ZRN anode shall not vary more than $\pm 1/32$ in. (1 mm) from the specified diameter.

9.9 The thickness of Types ZHS, ZHB, ZHC, ZTS, ZPN, ZSS, ZEP, and ZBP anodes shall not vary more than $\pm 1/8$ in. (3 mm). Thickness measurements shall be taken at random 1 in. (25 mm) from any edge of the anode by means of a suitable caliper avoiding any surface irregularities which would interfere with a representative measurement.

9.10 The thickness of Type ZDN anodes shall not vary more than $\pm 1/64$ in. (0.4 mm).

9.10.1 The cores of Type ZDM anodes shall be positioned axially and concentrically in the zinc disc. Eccentricity greater than 0.005 in. (0.13 mm) will not be permitted.

10. Workmanship, Finish, and Appearance

10.1 The zinc anodes shall be free of flash burrs, cracks, blow holes, pipes, and surface slag consistent with good commercial practice.

10.1.1 For anodes less than 2 in. (50 mm) thick, when measured with a straightedge placed diagonally across the opposite edges of the cast anode, the anode shall be free of shrinkage cavities exceeding $1/4$ in. (6 mm) in depth. Anodes 2 in. (50 mm) thick or more shall be free of shrinkage cavities exceeding $3/8$ in. (10 mm) in depth.

10.1.1.1 For Type ZPN anodes, shrinkage cavities shall be measured over a 12- by 12-in. (305- by 305-mm) area and shall not exceed the dimensions specified in 10.1.1.

10.1.2 Surface irregularities of the anode exceeding $1/8$ in. (3 mm) in depth shall not be permitted on either face of slab or disc type anodes unless at least $1/8$ in. (3 mm) of sound metal covers the entire strap of core area.

10.2 Types ZDM and ZRN anodes shall be smooth on their curved surfaces.

10.3 Metal core extensions from the anodes shall be smooth and free of sharp burrs. The cast-in cores shall have metallurgical bonds specified herein free of air pockets and inclusions consistent with good commercial practice.

10.4 The coatings specified in 5.1.1 shall be adherent and free from flaking. The coating shall adhere tenaciously to the surface of the base metal. When the coating is cut or pried into,

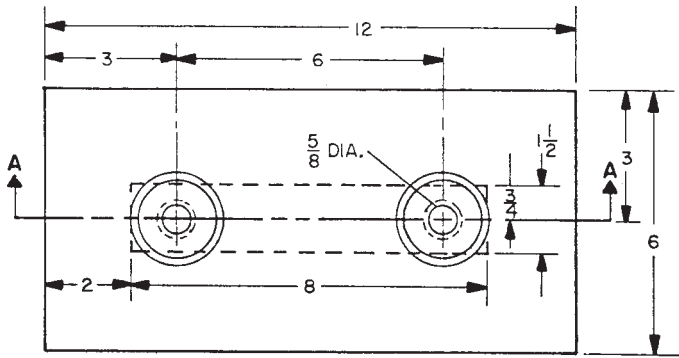

PLAN VIEW

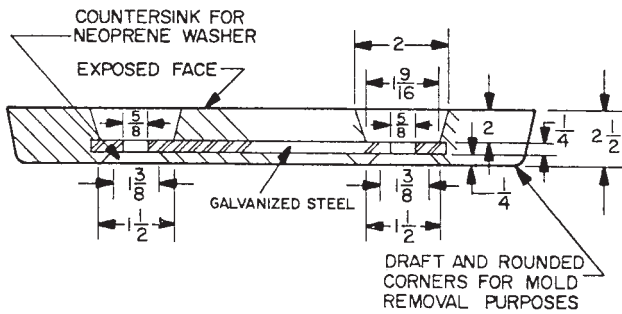

SECTION A-A

- NOTE 1—All dimensions are in inches.
- NOTE 2—Tolerance $\pm 1/8$ in.
- NOTE 3—1 in. = 25.4 mm.
- NOTE 4—Minimum weight 39 lb (18 kg).

FIG. 8 Zinc Hull Slab (Core Strap), Type ZHC-42, Submarine Application

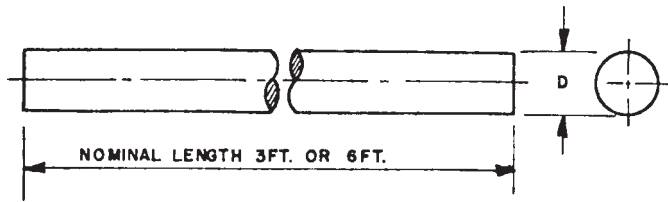

Nominal Diameter, D, in.	Iron Pipe Size, in.	Approximate Weight per Foot, lb (kg)
0.405	1/8	0.39 (0.17)
0.540	1/4	0.70 (0.31)
0.675	3/8	1.11 (0.50)
0.840	1/2	1.68 (0.76)
1.050	3/4	2.52 (1.13)
1.315	1	4.12 (1.85)

FIG. 9 Zinc, Rod (No Core), Type ZRN

such as with a stout knife applied with considerable pressure in a manner tending to remove a portion of the coating, it shall only be possible to remove small particles of the coating by paring or whittling, and it shall not be possible to peel any portion of the coating so as to expose the steel. Lack of

TABLE 1 Chemical Composition, Zinc Anodes (Galvanic Protectors)

Lead, % Max	Iron, % Max	Cad-mium, %	Cop-per, % Max	Alumi-num, %	Zinc, %
0.006	0.005	0.025-0.15	0.005	0.1-0.5	remainder

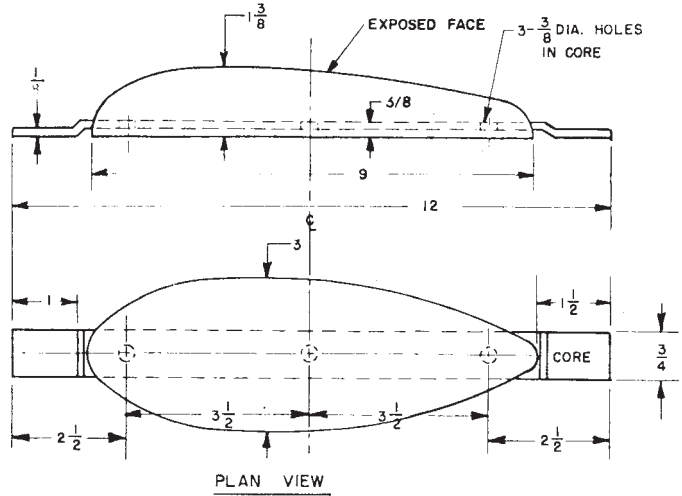

PLAN VIEW

- NOTE 1—Anode may be cast with exposed face in the up or down position. All dimensions are in inches.
- NOTE 2—Tolerance $\pm 1/8$ in.
- NOTE 3—1 in. = 25.4 mm.
- NOTE 4—Approximate weight is 5 lb (2.3 kg).

FIG. 10 Zinc, Teardrop (Steel Strap), Type ZTS

adhesion of the zinc coating at bends or absence of zinc coating at cut edges shall not be cause for rejection of fabricated anodes.

11. Sampling

11.1 For the purposes of sampling, a lot shall consist of all zinc anodes of the same class and type, poured or cast from one homogeneous heat or melt of a single charge of raw materials. The addition of any material to the heat or melt at any time constitutes a new lot.

11.2 Select a random sample of anodes from each lot in accordance with MIL-STD-105 at Inspection Level II for the examination specified in 14.1. In terms of defects per 100 units, the acceptable quality level (AQL) shall be 4.0 for total defects.

11.3 From each lot specified in 11.1, select two anodes at random of Types ZHS, ZHB, ZHC, ZSS, ZTS, ZEP, and ZBP and five anode discs of Type ZDM for the core bond tests specified in 13.1.1 or 13.1.2.

11.3.1 In cases in which one of the two anodes specified in 13.1.1 or 13.1.2 fails to pass the bond test, select four additional anodes for retest at the request of the manufacturer.

11.4 Select at random from the lot at least five each of both Type ZRN and ZPN anodes for the sampling for the physical testing described in 13.2.

11.5 The sampling for the chemical analysis described in 13.3 shall consist of anodes being selected at random in

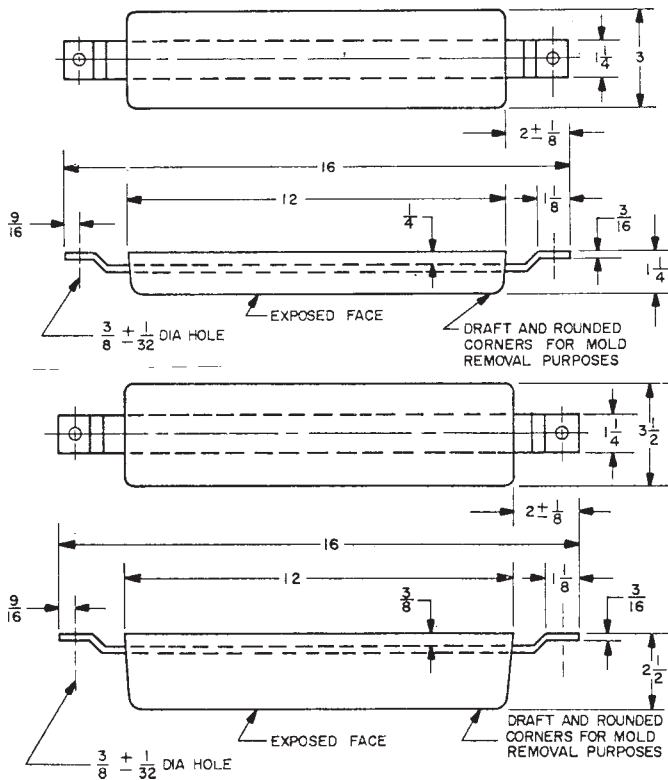

- NOTE 1—Anode may be cast with strap in the up or down position. All dimensions (inches) refer to the wider and longer dimensions of the anode.
- NOTE 2—Tolerances other than shown will be $\pm 1/8$ in.
- NOTE 3—Mounting holes in straps are optional and should be supplied only when specified.
- NOTE 4—1 in. = 25.4 mm.
- NOTE 5—Minimum weight 11 lb (5 kg).
- (top) Zinc, Submarine Slab (Steel Strap), Type ZSS-12
- NOTE 6—Anode may be cast with strap in the up or down position. All dimensions (in inches) refer to the wider and longer dimensions of the anode.
- NOTE 7—Tolerances other than shown will be $\pm 1/8$ in.
- NOTE 8—Mounting holes in straps are optional and should be supplied only when specified.
- NOTE 9—1 in. = 25.4 mm.
- NOTE 10—Minimum weight 21.5 lb (9.7 kg).
- (bottom) Zinc, Submarine Slab (Steel Strap), Type ZSS-24
- FIG. 11 Zinc, Submarine Slab (Steel Slab) Type ZSS**

accordance with 11.3, except that sufficient number of Type ZDM anodes shall be selected to comply with 12.1.5.

11.6 Discard sample anodes, except the remaining lengths of Type ZRN anodes, and do not include them in the delivery of material after the core bond tests specified in 13.1.1 and 13.1.2 are performed. Perform sampling for chemical analysis specified in 11.5 before discarding the anodes.

12. Specimen Preparation

12.1 From each anode selected for chemical analysis in accordance with 11.5, take one 2-oz (0.06-kg) sample by drilling or machining the material at the locations specified in 12.1.1-12.1.6, inclusive. The drilling or machining shall be done by the contractor. The drill or tool bit shall not penetrate into the core material of the cored type anodes. The drilled or

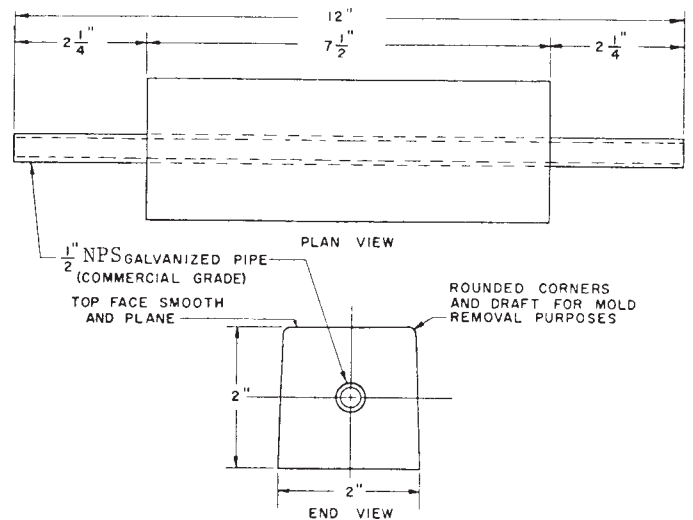

- NOTE 1—All dimensions, in inches, refer to the wider and longer dimensions of the anode.
- NOTE 2—Tolerance $\pm 1/8$ in.
- NOTE 3—1 in. = 25.4 mm.
- NOTE 4—Approximate weight is 8 lb (3.6 kg).
- NOTE 5—Unit of purchase—pound.
- NOTE 6—Unit of issue—each.

FIG. 12 Zinc, Bar (Pipe Core), Type ZBP

machined anodes may be included in the delivery of the material, except Type ZDM anode, which shall be discarded.

12.1.1 Drill or machine Types ZHS and ZHB anodes at locations about 2 to 5 in. (50 to 127 mm) from the short edge as appropriate to keep away from the encased core.

12.1.2 Drill or machine Types ZSS, ZHC, and ZTS anodes at points not greater than 1/2 in. (13 mm) from the long edge.

12.1.3 Drill Types ZEP and ZBP anodes at points midway between the outer edge of the core and the edge of the anode.

12.1.4 Drill Types ZRN and ZPN and have two 1-lb (0.45-kg) minimum sections cut from ends of a nominal length.

12.1.5 Type ZDM anodes shall have a sufficient number of discs machined or drilled at the outer surface to make two 4-oz (0.11-kg) quantities and shall be machined or drilled at the outer surface to a depth not exceeding 1/4 in. (6 mm).

12.1.6 Take one 2-oz (0.06-kg) sample for each anode specified in 12.1 at the surface in contact with mold wall by drilling or machining to a maximum of 1/4 in. (6 mm). Take the sample for Types ZPN or ZRN by drilling completely through both principal surfaces or through the diameter of the anode as applicable. Collect the samples in individual clean containers and properly label as to lot, melt, and sample numbers. Sample chips may be taken from anodes which have passed the applicable bond tests. Samples shall be clean, free from dirt, oil, grit, and foreign matter. Test the samples at a laboratory satisfactory to the contracting agency.

12.2 The drilling of samples for chemical analysis should be made with a special nonferrous drill in a clean location (used only for that purpose). Keep the drilling bits clean of dirt, grit, and other foreign matter; keep them properly sharpened; and use them only for sampling purposes. After each use, immerse the drilling bit in a degreasing solvent and wipe dry with a clean rag. Store the drilling bits, when not in use, in an

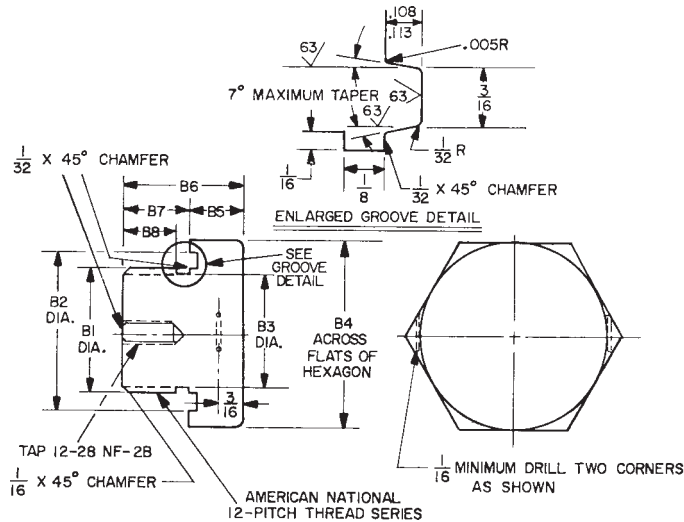

Zinc Coupon Diameter	B1 External Thread	B2	B3	B4	B5	B6	B7	B8
0.825	1 1/16-12 UN-2	1 7/16	1 5/16	1 11/16	1/2	1 1/8	5/8	1/2
1.050	1 5/16-12 UN-2	1 11/16	1 3/16	1 15/16	1/2	1 3/8	7/8	3/4

NOTE 1—All fractionable dimensions to have a tolerance of $\pm 1/64$ in.
 NOTE 2—All dimensions are in inches.
 NOTE 3—1 in. = 25.4 mm.

FIG. 13 Straight Thread O-Ring Seal Support Plug for ZDM Anode

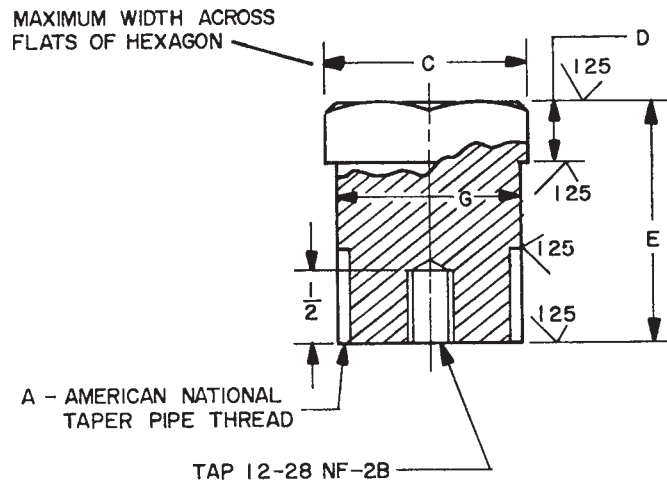

Nominal Pipe Size	A	C	D	E	G ± 0.003	Actual Diameter of Zinc Anode
1	1	1 1/2	1/2	1 3/8	1.315	1.050
3/4	3/4	1 1/4	3/8	1 1/8	1.050	0.825
1/2	1/2	1	3/8	1	0.840	0.625
3/8	3/8	3/4	5/16	1	0.675	0.500

NOTE 1—All fractionable dimensions to have a tolerance of $\pm 1/64$ in.
 NOTE 2—All dimensions are in inches.
 NOTE 3—1 in. = 25.4 mm.

FIG. 14 Tapered Pipe Thread Support Plug for ZDM Anode (Replacement Use Only, Not For New Construction)

inhibited lubricating oil. Keep this oil in a covered glass container provided with an air vent. Wipe the drilling bits dry with a clean rag prior to use. Take the samples with a dry drill.

If automatic power drilling is available, a solid tungsten carbide drill bit about 1/2 in. (13 mm) in diameter is suitable. Where a hand-held power drill is used, the drill bit should be

about 1/4 in. (6 mm) in diameter. A smaller drill bit may be used where the size of the anode does not permit using the specified diameters. The drills may be used at high speeds and feeds.

12.3 Make the chips for chemical analysis with a special nonferrous tool in a place which has been cleaned for that specific purpose. Instructions specified in 12.2 apply to the use and care of this tool.

12.4 Use a strong magnet to remove any iron contamination picked up during the preparation of the chips. Wash the chips in an iron-free degreasing solvent prior to the chemical analysis.

13. Test Methods

13.1 Perform one of the following core bonding tests on Types ZHS, ZHB, ZHC, ZSS, ZTS, ZEP, and ZBP anodes.

13.1.1 *Core bonding test*—Cut each anode selected to represent the lot along the axis of each strap or core, and ground the cut surface reasonably smooth. Polish these surfaces with a 240-mesh emery abrasive until the zinc-strap interface is distinctly visible. Examine this interface carefully at approximately 10 times magnification. The metallurgical bond between the zinc and the strap shall be continuous for at least 30 % of the surface in contact with the anode. Zinc anodes may have a bead or buttress projecting from the anode edge along the strap not exceeding 1/4 in. (6 mm). Less bond between the core and the zinc than specified herein shall be cause for rejection of the lot.

13.1.2 *Alternate Core Bonding Test*—Using any suitable method, tear the cores from each anode selected to represent the lot. The use of a sledge hammer to break the zinc away from the cores has been found to be satisfactory. Establish the area showing bond by visual inspection of the portion of the cores which were contained within the anode. Metallurgical bond between the zinc and the core shall be at least 30 % of the total surface area of each core in contact with the zinc of the anode. For the purpose of determining the surface area of the encased core in the anode, marks shall be scribed on the strap around the periphery of each anode at locations where the straps protrude from the anode. The total area of the strap shall be computed between the scribe marks. The surfaces shall have a smooth grey matte finish where bonding has been adequate and either a shiny metallic or rough, dark, or discolored finish where bonding has been inadequate. Examine both core and zinc mating surfaces. Less bond between core and zinc than that specified herein shall be cause for rejection of the entire lot.

13.1.3 A steady load of 750 lb (340 kg) from a hand operated pen press applied axially shall be required to remove the core from Type ZDM anode.

13.2 Types ZRN and ZPN anodes, selected in accordance with 11.4, shall be bent 45° around a mandrel of three times the diameter of the ZRN type anode and three times the thickness of the ZPN plate. Bend the anodes in accordance with procedures specified in Test Method E 290. After bending, inspect the convex surface of the specimens for cracking by visual examination. Any evidence of cracking shall represent failure of the test and shall be cause for rejection of the entire lot.

13.2.1 Subject the ZRN anodes specified in 13.2 to torsional shear at a rate of ten to twelve revolutions per hour using a torsional shear apparatus. Failure of the anode to withstand a torsional shear of 12 000 psi (83 MPa) shall be cause for rejection of the lot.

13.3 Analyze the chips selected in accordance with 11.5 to determine conformance with 6.1. If any sample does not conform to the chemical composition specified in Table 1, it shall be cause for rejection of the lot represented by the sample.

13.3.1 Determine the aluminum, cadmium, copper, iron, and lead content of zinc in accordance with the appropriate methods in Test Method E 536 using the atomic absorption spectrophotometer.

13.3.2 A spectrochemical analysis shall be in accordance with any applicable ASTM standard method and accepted by the purchaser.

14. Inspection

14.1 Each anode selected in accordance with 11.2 shall be visually examined for workmanship and dimensions. Where the number of anodes that do not conform to the requirements of Sections 7, 9, 10, and 16 is equal to or greater than the rejection number specified in 11.2 (AQL = 4.0), it shall be cause for rejection of the entire lot.

15. Certification

15.1 When specified in the contract or purchase order (see 4.1.12), a manufacturer's or supplier's certification shall be furnished to the purchaser stating that samples representing each lot have been manufactured, tested, and inspected in accordance with this specification and the requirements have been met. When specified in the contract or purchase order, a report of the test results shall be furnished.

16. Product Marking

16.1 The zinc anodes, Types ZHS, ZHB, ZHC, ZSS, and ZBP, shall have the words "DO NOT PAINT" die-stamped or cast on the exposed face of the anodes (see Fig. 3, Fig. 4, Fig. 7, Fig. 11, and Fig. 12). These words are not required on Types ZEP, ZPN, ZDM, ZTS, and ZRN zinc anodes.

16.1.1 One end of each cast-in strap of each Type ZHB anode shall be painted red so that the installing activity can distinguish it from Type ZHS anodes. One coat of red paint shall be applied between the joggled bevel of the strap and zinc anode. The coating shall be approximately 1/2 in. (13 mm) wide and shall extend across one side of each strap so as to be readily visible when the anode is installed. The foot of the strap shall not be painted.

16.2 All anodes shall be cast, die-stamped, or scribed with the following: manufacturer's symbol, unique non-recurring heat number, and numbers and letters corresponding to this ASTM specification (including revision designation).

17. Packaging

17.1 Unless otherwise specified (see 4.1.13), packaging shall conform to manufacturer's normal commercial practice, and in such a manner that will ensure acceptance by common carrier and afford protection against physical and mechanical

damage during shipment. Shipping containers shall conform to carrier regulations as applicable to the mode of transportation.

18. Keywords

18.1 anodes; disc anodes; plate anodes; rod anodes; sacrificial anodes; slab anodes; zinc alloy anodes

SUPPLEMENTARY REQUIREMENTS

The following supplementary requirements shall apply for government contracts or when specified by the purchaser in the contract or purchase order (see 4.1.13).

S1. Referenced Documents

S1.1 The following documents are applicable only when one or more of the requirements of S2 are specified in the contract or purchase order (see 4.1.13): Practice D 3951; MIL-P-15011; MIL-STD-129; MIL-STD-1186; and Fed. Specs. PPP-B-601, PPP-B-621, and PPP-B-636.

S2. Packaging and Package Marking

S2.1 Preservation shall be Level A, C, or commercial, as specified (see 4.1.13).

S2.1.1 *Level A*—Type ZEP, Styles A and B (2- to 6-in. (51- to 152-mm) diameter, inclusive) and Type ZDM anodes shall be packaged in quantities specified in Table S1.1, unless otherwise specified (see 4.1.13), and snugly fitted into fiberboard boxes in accordance with Federal Specification PPP-B-636, class water resistant. ZEP anodes shall be immobilized within the boxes with solid fiberboard or other suitable separators so that cast-in cores cannot be loosened by impact or heavy loading. The gross weight of the boxes shall not exceed the weight limitations of the fiber box specifications.

S2.1.2 *Level C*—The zinc anodes shall be preserved as specified for Level A, except that nonweather resistant domestic grade fiberboard boxes may be used.

S2.1.3 *Commercial*—Anodes shall be preserved in accordance with Practice D 3951.

S2.2 Packing shall be Level A, B, or commercial, as specified (see 4.1.13).

S2.2.1 *Level A*—Anodes, segregated for type, size, and heat, shall be packed in accordance with S2.2.1.1 through S2.2.1.6.

S2.2.1.1 Types ZHS, ZHB, ZHC, ZTS, ZPN, ZSS, ZBP, and ZEP (Style B in sizes 9- and 11-in. (229- and 279-mm) diameter and Style C) anodes shall be packed in unit pallet loads or in boxes in accordance with S2.2.1.2 and S2.2.1.3.

S2.2.1.2 Pallets shall be in accordance with MIL-P-15011. The anodes shall be secured to the pallet with tension tied, coated or galvanized, steel strapping applied lengthwise and girth-wise. Minimum size of the strapping shall be 0.075 by 0.035 in. (20 by 10 mm). The gross weight of the pallet load shall not exceed 3000 lb (1362 kg).

S2.2.1.3 The boxes shall be in accordance with Federal Specifications PPP-B-601 (overseas type) or PPP-B-621, Class 2. The gross weight of the box shall not exceed approximately 500 lb (227 kg). Box closure and strapping shall be in accordance with the applicable box specification or appendix thereto. The boxes shall be modified by the addition of skids, for gross weights exceeding 200 lb (91 kg), in accordance with the applicable box specification.

S2.2.1.4 Types ZEP, Style A and B in sizes 2- to 6-in. (51- to 152-mm) diameter inclusive, and ZDM anodes packaged as specified in S2.1.1, shall be packed and snugly fitted into nailed wood or wood-cleated plywood boxes in accordance with Federal Specifications PPP-B-621, Class 2, or PPP-B-601 (overseas type), respectively. The gross weight of shipping containers shall not exceed approximately 200 lb (91 kg).

S2.2.1.5 Type ZRN anodes shall be packed as specified in S2.2.1.3.

S2.2.1.6 The anodes shall be cushioned, blocked, and braced in accordance with MIL-STD-1186.

S2.2.2 *Level B*—Anodes, segregated for type, size, and heat, shall be packed in accordance with S2.2.2.1 through S2.2.2.6.

S2.2.2.1 Types ZHS, ZHB, ZHC, ZTS, ZPN, ZSS, ZBP, and ZEP (Style B in sizes 9- and 11-in. (229- and 279-mm) diameter and Style C) anodes shall be packed in unit pallet loads or in boxes in accordance with the following:

S2.2.2.2 Pallets shall be as specified in S2.2.1.2.

S2.2.2.3 The boxes shall be in accordance with Federal Specifications PPP-B-621, Class 1, or PPP-B-601 (domestic type). The gross weight of the box shall not exceed approximately 500 lb (227 kg). Box closure shall be in accordance

TABLE S1.1 Level A Packaging of Type ZEP and ZDM Anodes

Anode	Number per Package	Net Weight per Package, lb (kg)
Type ZEP, Style A	5	45 (20)
Type ZEP, Style B:		
Diameter, in.		
6	5	36 (16)
5	5	25 (11)
4	10	32 (15)
3	20	36 (16)
2	40	32 (15)
Type ZDM, NPS, in.		
1	50	8 (4)
3/4	100	10 (5)
1/2	200	12 (5)
3/8	200	8 (4)

with the applicable box specification or appendix thereto. The boxes shall be modified by the addition of skids, for gross weights exceeding 200 lb (91 kg), in accordance with the applicable box specification.

S2.2.2.4 Types ZEP, Style A and Style B in sizes 2- to 6-in. (51- to 152-mm) diameter inclusive, and ZDM anodes, packaged as specified in S2.1.1, shall be packed and snugly fitted into nailed wood and wood-cleated plywood boxes in conformance with Federal Specifications PPP-B-621, Class 1, or PPP-B-601 (domestic type), respectively. The gross weight of shipping containers shall not exceed approximately 200 lb (91 kg).

S2.2.2.5 Type ZRN anodes shall be packed in accordance with S2.2.1.5, except wood or wood-cleated containers shall be of the domestic type and for Type 3 load in accordance with Federal Specification PPP-B-601.

S2.2.2.6 The anodes shall be cushioned, blocked, and braced so as to prevent damage during shipment.

S2.2.3 *Commercial*—Zinc anodes that require overpacking for shipment shall be packed in accordance with Practice D 3951.

S2.3 *Marking*—In addition to any special marking required by the contract or purchase order (see 4.1.13), Level A, B, and C packs, pallet loads, and shipping containers shall be marked in accordance with MIL-STD-129. Commercial packs, pallet loads, and shipping containers shall be marked in accordance with Practice D 3951.

S3. Inspection

S3.1 The packaging, packing, and package marking of the anodes shall be inspected to verify compliance with the requirements of Section S2.

S3.2 The contractor is responsible for the performance of all inspection requirements as specified herein. Except as otherwise specified in the contract or purchase order, the contractor may use his own or any other facilities suitable for the performance of the inspection requirements specified herein, unless disapproved by the purchaser. The purchaser reserves the right to perform any of the inspections set forth in the specification where such inspections are deemed necessary to ensure supplies and services conform to prescribed requirements.

The American Society for Testing and Materials takes no position respecting the validity of any patent rights asserted in connection with any item mentioned in this standard. Users of this standard are expressly advised that determination of the validity of any such patent rights, and the risk of infringement of such rights, are entirely their own responsibility.

This standard is subject to revision at any time by the responsible technical committee and must be reviewed every five years and if not revised, either reapproved or withdrawn. Your comments are invited either for revision of this standard or for additional standards and should be addressed to ASTM Headquarters. Your comments will receive careful consideration at a meeting of the responsible technical committee, which you may attend. If you feel that your comments have not received a fair hearing you should make your views known to the ASTM Committee on Standards, at the address shown below.

This standard is copyrighted by ASTM, 100 Barr Harbor Drive, PO Box C700, West Conshohocken, PA 19428-2959, United States. Individual reprints (single or multiple copies) of this standard may be obtained by contacting ASTM at the above address or at 610-832-9585 (phone), 610-832-9555 (fax), or service@astm.org (e-mail); or through the ASTM website (www.astm.org).