

MATERIAL AND EQUIPMENT STANDARD**FOR****CATHODIC PROTECTION****ORIGINAL EDITION****DEC. 1997**

This standard specification is reviewed and updated by the relevant technical committee on March 2006. The approved modifications are included in the present issue of IPS.

0. INTRODUCTION

This Standard consists of fourteen parts, as listed hereunder:

- Part 1 : Impressed Current Anodes
- Part 2 : Carbonaceous Backfill for Impressed Current Anodes
- Part 3 : Galvanic Anodes for Underground Applications (Magnesium and Zinc)
- Part 4 : Galvanic Anodes for Submerged Applications (Magnesium and Zinc)
- Part 5 : Bracelet Type Galvanic Anodes for Submarine Pipelines (Aluminum and Zinc)
- Part 6 : Cast Galvanic Anodes for Fixed Offshore Installations (Aluminum)
- Part 7 : Cathodic Protection Cables
- Part 8 : Insulating Joint
- Part 9 : Flange Insulation Kit
- Part 10: Polypropylene Rope
- Part 11: Splicing Kit
- Part 12: Split Bolt Connector (Line Tap)
- Part 13: Splice Coating Materials
- Part 14: Thermit Weld (CAD Weld) Powder

PART 1**IMPRESSED CURRENT ANODES**

CONTENTS :	PAGE No.
1. SCOPE	4
2. REFERENCES	4
3. UNITS	5
4. TECHNICAL DOCUMENTS	5
5. MATERIALS AND MANUFACTURE	6
6. ANODE CASTING	6
7. LEAD WIRE-TO-ANODE CONNECTION	7
8. ANODE LEAD WIRE	8
9. PROPERTIES	9
10. DIMENSIONS AND WEIGHTS	10
11. SAMPLING	12
12. REJECTION	12
13. INSPECTION	12
14. CERTIFICATION	12
15. PACKAGING AND SHIPMENT	13
16. LABELING	13
 APPENDICES:	
APPENDIX A DATA SHEET FOR HIGH-SILICON-IRON ANODES	15
APPENDIX B DATA SHEET FOR GRAPHITE ANODES	16
APPENDIX C DATA SHEET FOR MAGNETITE ANODES	17

1. SCOPE

This Part of [IPS-M-TP-750](#) covers the minimum requirements for anodes (High-Silicon-Iron, Graphite, Magnetite) for use in impressed current cathodic protection systems. It specifies the composition, materials, manufacture, properties, inspection and testing for High-Silicon-Iron, Graphite and Magnetite anodes. The specification covers only general requirements for the anodes, the specific requirements will be given in pertinent ordering documents by the Purchaser (see Appendices A, B and C).

Note:

This standard specification is reviewed and updated by the relevant technical committee on March 2006. The approved modifications by T.C. were sent to IPS users as amendment No. 1 by circular No. 310 on March 2006. These modifications are included in the present issue of IPS.

2. REFERENCES

Throughout this Standard the following dated and undated standards/codes are referred to. These referenced documents shall, to the extent specified herein, form a part of this standard. For dated references, the edition cited applies. The applicability of changes in dated references that occur after the cited date shall be mutually agreed upon by the Company and the Vendor. For undated references, the latest edition of the referenced documents (including any supplements and amendments) applies.

ASTM (AMERICAN SOCIETY FOR TESTING AND MATERIALS)

A 256	Standard Method of "Compression Testing of Cast Iron"
A 327	Standard Method of "Impact Testing of Cast Iron"
A 518M	Standard Specification for "Corrosion-Resistant High-Silicon Iron Casting"
B 8	Standard Specification for "Concentric-Lay-Stranded Copper Conductors, Hard, Medium-Hard, or Soft"
B 193	Standard Test Method for "Resistivity of Electrical Conductor Materials"
B 539	Standard Test Method for "Measuring Contact Resistance of Electrical Connections (Static Contact)"
D 1047	Standard Specification for "Poly (Vinyl Chloride) Jacket for Wire and Cable"
D 1248	Standard Specification for "Polyethylene Plastics Molding and Extrusion Materials"
D 2308	Standard Specification for "Polyethylene Jacket for Electrical Insulated Wire and Cable"
D 2655	Standard Specification for "Crosslinked Polyethylene Insulation for Wire and Cable Rated 0 to

	2000 V"
D 3032	Standard Test Methods for "Hookup Wire Insulation"
E 10	Standard Test Method for "Brinell Hardness of Metallic Materials"
E 94	Standard Guide for "Radiographic Testing"
E 802	Standard Reference Radiographs for "Gray Iron Casting up to 114 mm (4½ in.) in Thickness"

IEC (INTERNATIONAL ELECTROTECHNICAL COMMISSION)

228	"Conductors of Insulated Cables"
-----	----------------------------------

ISO (INTERNATIONAL ORGANIZATION FOR STANDARDIZATION)

2859	"Sampling Procedures for Inspection by Attributes" Part 1: Sampling Plans Indexed by Acceptable Quality Level (AQL) for Lot-by-Lot Inspection
------	---

3. UNITS

This Standard is based on International System of Units (SI), except where otherwise specified.

4. TECHNICAL DOCUMENTS

The technical bid shall include the following with reference to data sheet (see Appendices).

4.1 Catalogue (including technical data of the offered anodes).

4.2 Production procedures that cover all stages of the manufacturing process, from receipt of raw materials to finishing and packing for shipment, including:

- chemical analysis;
- measurements of weight, dimensions, etc.;
- inspection and testing procedures and frequencies;
- anode manufacture;
- anode connections.

4.3 Anodes consumption rates at maximum applicable current density in different environments (e.g., sea water, fresh water, soil, etc.).

4.4 Full information about anode lead wire indicating product identification number, construction details, voltage rating of primary insulation, physical properties of the primary insulation and jacket material including tensile strength and ultimate elongation of finished wire, insulation resistance of primary insulation, notch propagation of the finished wire, abrasion resistance of the finished wire, concentricity tolerance of the finished wire, and continuous service temperature limits of the finished product.

4.5 Preservation, packing and shipping procedures, such that anodes are not damaged or deformed and do not deteriorate during handling, delivery to the fabrication yard, storage: including methods, materials and any requirement for periodic inspections.

5. MATERIALS AND MANUFACTURE

5.1 Manufacturing of anodes shall be carried out using approved production procedures covering each stage of the process from supply of raw materials to finishing and packing for shipment. The procedures shall be fully referenced in an inspection and test plan which shall also refer to requirements of this Standard specification, as applicable.

5.2 The manufacturer shall ensure that full traceability of all the materials is maintained throughout manufacturing process.

5.3 The quality control at the anode manufacturing plant shall include control systems on the following:

- Raw materials, i.e. checking of documentation.
- Production equipment and process.
- Testing during and after production.
- Identification of anodes.
- Chemical analysis.
- Weight and dimensional tolerances.
- Surface condition of produced anodes.
- Documentation (material certificates).

5.4 The manufacturer shall submit to the Purchaser his quality assurance and control plan.

6. ANODE CASTING

6.1 Casting of High-Silicon-Chromium-Iron Anode

6.1.1 Anodes shall be made from High-Silicon-Chromium-Iron casting conforming to the ASTM A 518M-86 (Grade 3) and shall have either a solid or "rod type" configuration with the anode lead attached at one end of the anode or a "tubular type" configuration with the anode lead attached at the center of the anode.

6.1.2 The casting may be produced by any process at the option of the manufacturer, capable of meeting the chemical composition and physical properties specified.

6.1.3 Where solid or "rod type" anodes are required, the anode shall be single end with enlarged head. The anode's enlarged head shall be cored to provide cavities for lead wire connection.

6.1.4 Where "tubular type" anodes are required, the anode shall be hollow, straight-walled tubular anode having walls of uniform thickness and having an open cylindrical interior for lead wire connection.

6.1.5 The casting shall be dense and homogeneous ensuring that the anode properties are uniform throughout their length.

6.1.6 The chemical composition of the anode alloy content shall conform to the limits prescribed in Table 1.

6.2 Casting of Graphite Anode

6.2.1 Anodes shall be of the plain graphite type extruded in circular or square shapes. They shall be of the "treated type", having been impregnated with linseed oil by a vacuum-pressure autoclave process.

6.2.2 The graphitizing ovens shall be so designed to ensure that a uniform internal graphite structure is obtained as well as an overall consistency from one anode to another.

Note:

If great care is not taken during the manufacturing process, internal cracks and flaws may develop in the graphite. It is therefore necessary that the manufacturer takes the necessary steps to maintain a consistent material free from internal and external flaws.

6.2.3 The aggregate and grain shall be small and shall have similar physical, chemical and electrical properties. The material shall be free of voids and impurities.

6.2.4 The anodes shall be sufficiently resistant to permit firm tamping of backfill around them and immune to chemical attack.

6.2.5 Anodes shall have one end drilled for cable connection.

6.3 Casting of Magnetite Anode

6.3.1 Anodes shall be made by casting the magnetite (Fe_3O_4) with the melting point of about 1540°C , plus an addition of small quantities of alloying elements, into a hollow cylinder closed at one end. The whole inside surface of the anode shall be coated with a plated thin copper layer. 100 mm below the anode top a copper tag shall be fixed to the inside copper layer for cable attachment.

The anode body shall be filled with a soft plastic core (e.g., polystyrene or polyurethane) to absorb the differential rates of expansion of the resin and the magnetite.

6.3.2 Casting may be produced by any process at the option of the manufacturer, capable of meeting the requirements specified herein.

6.3.3 The casting shall be dense, and homogeneous ensuring that the anode properties are uniform throughout their length.

7. LEAD WIRE-TO-ANODE CONNECTION

7.1 The anodes shall be supplied complete with lead wires (see 8) connected to the casting.

7.2 For "rod type" High-Silicon-Iron anodes, the method of connecting the lead wire to the anode shall either be by leading and tamping (caulked lead connection), or by the use of a tapered pin connection.

7.3 For Graphite anodes, the method of connecting the lead wire to the anode shall either be by a brass soldered, or by the use of a compression connection.

7.4 For Magnetite anodes, the method of connecting the lead wire to the anode copper conducting layer shall be by the use of a brazed connection.

7.5 The anode lead to anode connection shall be fully sealed to prevent water intrusion by application of an epoxy compound. Finally an internally mastic lined heat shrink cap which covers the anode head 75 mm minimum and the lead wire 50 mm minimum, shall be applied and shrunk into place to provide a complete water-tight and leak-free seal capable of withstanding sever service conditions.

7.6 Heat shrink anode cap used for sealing the anode lead connection, as will be specified by the Purchaser, shall be either standard or chlorine resistant type in accordance with following:

Standard Type:

Heat-shrinkable polyethylene

Chlorine Resistant Type: Heat-shrinkable polyvinylidene fluoride

7.7 For "tubular type" High-Silicon-Iron anodes, the type and method of connecting and sealing the lead wire to the anode shall be approved by the anode manufacturer.

Note:

The internal moisture seal must withstand the hydrostatic pressure and resist degradation from oxidizing gases released at the anode.

8. ANODE LEAD WIRE

8.1 Conductor

The copper conductors shall be single core stranded, compressed, soft annealed, uncoated copper in accordance with ASTM specification B8 Class B or IEC Publication 228 Class 2.

Unless otherwise specified by the Purchaser, the lead wire size shall be 10 mm².

Unless otherwise specified by the Purchaser, the lead wire length shall be 3 meters.

8.2 Lead Wire Insulation

The lead wire insulation, as will be specified by the Purchaser (see Appendices A, B and C), shall be either standard or chlorine resistant type and shall conform to one of the following types:

8.2.1 Standard type insulation

The insulation shall be in accordance with one of the following alternatives:

8.2.1.1 A single jacket of High Molecular Weight Polyethylene insulation complying with the physical and electrical requirements of ASTM Specification D 1248, Type I, Class C, Category 5, Grade J3, having an average insulation thickness of 2.8 mm.

8.2.1.2 A double jacket of High Molecular Weight Polyethylene primary insulation complying with the physical and electrical requirements of ASTM Specification D 1248, Type 3, Class C, Category 5, Grade J3; sheathed with a chemical and abrasion resistant Polyvinyl Chloride (PVC) extruded jacket conforming to ASTM specification D 1047. The average thickness shall be 2.8 mm.

8.2.1.3 A double jacket of chemically Cross-Linked Polyethylene (XLPE) primary insulation conforming to ASTM specification D 2655, sheathed with a chemical and abrasion resistant Polyvinyl Chloride (PVC) extruded jacket conforming to ASTM specification D 1047. The average thickness shall be 2.8 mm.

Note:

In the case of local purchasing which the anode lead wire with the above insulation material may not be available, a double jacket PVC/PVC insulation are also acceptable, subject to Company approval.

8.2.2 Chlorine resistant type insulation

The insulation shall be in accordance with one of the following alternatives:

8.2.2.1 A single jacket of modified Polyvinylidene Fluoride (PVDF), double extruded insulation, having a minimum insulation thickness of 0.75 mm.

8.2.2.2 A double jacket of a radiation Cross-Linked Polyvinylidene Fluoride (XLPVDF), primary insulation, sheathed with a chemical and abrasion resistant High Molecular Weight Polyethylene extruded jacket conforming to ASTM specification D 2308. The minimum thickness shall be $0.5 + 1.7 = 2.2$ mm.

8.3 Lead wire insulation shall have a minimum of 600 Volt rating.

8.4 The minimum thickness at any point shall not be less than 90% of the specified average thickness.

8.5 The insulation shall provide continuous coverage, adequate dielectric properties, and have a high resistant to abrasion, stress cracking, notch propagation*, and notch sensitivity.

8.6 Unless otherwise specified by the Purchaser, the color of anode lead wire insulation shall be fade-resistant black for standard type and fade-resistant red for chlorine-resistant type.

9. PROPERTIES

The finished product shall meet the following requirements:

9.1 Workmanship, Finish, and Appearance.

9.1.1 Anodes shall be free from defects which may impair the performance of the finished component. Anodes shall be free of flaws, slags, cracks, blow holes, and excessive porosity consistent with good commercial practice.

9.1.2 The lead wire insulation shall be continuous having a thickness as uniform as possible and shall be completely free of nicks, scratches, or other discontinuities.

*** Notch propagation: The tendency of a cut, nick, or scratch in a material to increase in depth and/or length when the material is stressed.**

9.2 Mechanical Resistance Test

When an uniaxial force equivalent to 100 kg, or five times the mass of the anode metal, whichever is the greater, is applied to a cast anode, it shall not result in damage to the cable or its connections.

9.2.2 The Silicone –iron alloy shall meet transverse bond test results (according to test method A518/A518 M and acceptance test criteria)

9.3 Electrical Resistance Test

The electrical resistance at the connection of a completely assembled anode, shall not exceed 0.03 ohms, when tested in accordance with ASTM test method B 539.

Note:

Connection resistance is defined as total resistance minus resistance of the anode cable.

9.4 Temperature Dependence

Anodes shall not have a tendency of cracking when affected by alternating high and low temperatures.

9.5 Fluoropolymer Insulated Anode Lead Wire Test

The Fluoropolymer insulation used on anode lead wire must pass the impulse dielectric test** performed in accordance with ASTM D 3032, Section 12, at 600 Volts (peak) per 0.025 mm or a

maximum of 18 kilovolts (peak).

If an outer jacket of fluoropolymer or other material is applied, all finished wire must pass the impulse dielectric test at a voltage equal to 600 Volts (peak) per 0.025 mm of primary insulation plus 100 Volts (peak) per 0.025 mm of the jacket thickness or a maximum of 18 kilovolts (peak).

9.6 Radiographic Test

The anode shall show no internal defects when tested by means of X-ray in accordance with ASTM Guide E94. Types and degrees of discontinuities considered shall be judged by reference radiographs ASTM E 802.

9.7 In addition the "rod type" High-Silicon-Iron anodes shall conform to the requirements for physical properties prescribed in Table 2.

TABLE 1 - CHEMICAL COMPOSITION LIMITS FOR HIGH-SILICON-IRON ANODES

ELEMENT	COMPOSITION, wt%	METHOD OF ANALYSIS
Carbon	0.9-1.0	ASTM A 518M
Manganese	1.5 max.	
Silicon	14.25 - 14.75	
Chromium	4.3 - 5.00	
Molybdenum	0.2 max.	
Copper	0.50 max.	
Iron	Remainder ^{a)}	

a) Determined arithmetically by difference.

**** Impulse dielectric test: A method of applying voltage to an insulated wire through the use of electric pulses (usually 170 to 250 pulses per second) to determine the integrity of the wire's insulation.**

TABLE 2 - PHYSICAL PROPERTIES OF "ROD TYPE" HIGH-SILICON-IRON ANODES

PROPERTY	UNIT	REQUIREMENT	TEST METHOD ASTM
Density	g/cm ³	7 - 7.05	Approved method
Hardness, Brinell (min)	---	500	E 10
Compressive strength (min)	MPa	650	A 256
Electrical resistivity (max)	$\mu\Omega \cdot \text{cm}$	72	B 193
Impact resistance (min)	J	0.1	A 327 (Charpy Type)

10. DIMENSIONS AND WEIGHTS

10.1 The dimensions and weights of High-Silicon-Iron "rod type" anode; as will be specified by the Purchaser, shall be in accordance with Table 3.

TABLE 3 - DIMENSIONS OF HIGH-SILICON-IRON ANODES ("ROD TYPE")

DIAMETER (NOMINAL) mm	HEAD DIAMETER (NOMINAL) mm	LENGTH (NOMINAL) mm	WEIGHT (NOMINAL) kg
51	76	915	14.5
51	76	1220	19
51	76	1525	22.5
76	102	915	29
76	102	1220	38
76	102	1525	49

10.2 The dimensions and weights of High-Silicon-Iron "tubular type" anode, as will be specified by the Purchaser, shall be in accordance with Table 4.

TABLE 4 - DIMENSIONS OF HIGH-SILICON-IRON ANODES ("TUBULAR TYPE")

OUTSIDE DIAMETER mm	INSIDE DIAMETER mm	WALL THICKNESS mm	LENGTH (NOMINAL) mm	WEIGHT (NOMINAL) kg
67	47	10	1067	14
56	36	10	2134	21
67	47	10	2134	29
95	75	10	2134	39
121	100	10	2134	50
121	86	17	2134	79

10.3 The dimensions and weights of Graphite anode, as will be specified by the Purchaser, shall be in accordance with Table 5.

TABLE 5 - DIMENSIONS OF GRAPHITE ANODES

DIAMETER (NOMINAL) mm	LENGTH (NOMINAL) mm	WEIGHT (NOMINAL) kg
76	1525	11
102	2032	28
152	1830	53

10.4 The dimensions and weight of Magnetite anode shall be as follows:

Overall length	: 800 mm
Effective length	: 740 mm
Outside diameter	: 60 mm
Inside diameter	: 40 mm
Total weight	: 6.0 kg
Magnetite weight	: 4.7 kg

10.5 The actual dimensions shall conform to the following:

10.5.1 Anode mean length shall be $\pm 3\%$ of nominal length or ± 25 mm, whichever is smaller.

10.5.2 The diameter of anode shall be $\pm 5\%$ of nominal diameter.

10.5.3 The permissible variation in weight of each finished anode shall be $\pm 5\%$ of the nominal weight.

11. SAMPLING**11.1 Lot**

Unless otherwise specified by the Purchaser, a lot shall consist of all anodes made from the same production run offered for inspection at one time.

11.2 Sampling for Inspection

Sample anodes shall be selected from each lot in accordance with inspection Level II of ISO 2859 (Part 1). The acceptable quality level shall be 4 percent for all visual, dimensional and weight defects combined and 2.5 percent for all other type of defects with reference to this Part of Standard specification. The single sampling plans for normal inspection (Table II A of ISO 2859 Part 1) shall be used.

12. REJECTION

Where the numbers of anodes that do not conform to this Part of Standard specification exceed the acceptance numbers specified in 11.2, this shall be cause for rejection of entire lot.

13. INSPECTION

13.1 The manufacturer and/or supplier shall be responsible for carrying out all the tests and inspections required by this Part of Standard specification, using his own or other reliable facilities, and he shall maintain complete records of all such tests and inspections. Such records shall be available for review by the Purchaser.

13.2 The manufacturer and/or supplier shall afford the purchaser's inspector all reasonable facilities necessary to satisfy him that the material is being produced and furnished in accordance with this Part of Standard specification. Such inspections in no way relieve the manufacturer and/or supplier of his responsibilities under the terms of this Standard specification.

13.3 The Purchaser reserves the right to perform any inspections set forth in this Part of Standard specification where such inspections are deemed necessary to assure that supplies and services conform to the prescribed requirements.

13.4 The Purchaser's inspector shall have access to the material subject to inspection for the purpose of witnessing the selection of the samples, the preparation of the test samples, and the performance of the tests. For such tests, the inspector shall have the right to indicate the pieces from which the samples will be taken in accordance with the provisions of this Part of Standard specification.

14. CERTIFICATION

14.1 The manufacturer shall provide the Purchaser with a certification stating that the anodes meet the specified requirements of this Part of Standard specification.

14.2 The test report shall contain results of tests required by this Part of Standard specification and other tests specified by the Purchaser.

14.3 Each test report shall be signed by an authorized agent of the seller and/or manufacturer.

14.4 Certified test reports furnished by the manufacturer shall be properly identified with each lot (batch) of products.

15. PACKAGING AND SHIPMENT

15.1 Anodes shall be bundled, strapped, placed on pallets or in sturdy crates with supports, pads and binding as necessary to facilitate unloading and minimize damage to anodes during normal handling and transportation.

15.2 Cables shall be carefully coiled and positioned inside the crates or on the pallets so that no cable damage can occur during loading and transportation. Under no circumstances must anodes lay on the cables.

15.3 Cleaning, preservation, and packaging of anodes shall be in accordance with the manufacturer's commercial practice, provided they are such as to ensure acceptance by common or other carriers for safe transportation to the delivery point.

16. LABELING

16.1 Anode Identification

Each anode casting shall be stamped with the following:

- Name and/or trademark of the manufacturer.
- Batch number.
- Cast number.
- Alloy type (i.e., High-Silicon-Iron, Graphite, or Magnetite).

16.2 Lead Wire Identification

The lead wire shall be marked with the following information:

- Manufacturer's name.
- Lead wire size.
- Lead wire insulation.
- Specification.

16.3 Marking of Containers

Each crate or pallet shall be plainly marked with the following information:

- Name of anode : (i.e., High-Silicon-Iron, Graphite, or Magnetite) anode
- Specification : [IPS-M-TP-750](#): Part 1
- Order No. :
- M.E.S.C. No. :
- Anode type :
- Anode Dimensions : Length..... mm, Diameter mm, Weight kg.
- Batch No. :
- Stock No. :
- Date of Manufacture :
- Quantity :
- Manufacturer's name and address :

Note:

Each crate or pallet shall be clearly marked "FRAGILE".

APPENDICES

**APPENDIX A
DATA SHEET**

(TO BE SUBMITTED BY THE PURCHASER)

FOR

IPS-M-TP-750: Part 1 HIGH-SILICON-IRON ANODES

The anodes shall be in accordance with the latest edition of above Iranian Petroleum Standard with following specific requirements:

- Project title: - Date:
- Indent No.: - Purchaser:
- M.E.S.C. No.:
- Quantity:
- Type of anode:
 - b "Rod Type"
 - b "Tubular Type"
- Anode dimensions:
- Anode cap type:
 - b Standard
 - b Chlorine resistant
- Lead wire insulation type:
 - Standard type:
 - b Double Jacket - PVC/PVC (see Note of 8.2.1)
 - b Single Jacket - HMWPE
 - b Double Jacket - HMWPE/PVC
 - b Double Jacket - XLPE/PVC
 - Chlorine resistant type:
 - b Single Jacket - PVDF
 - b Double Jacket - XLPVDF/HMWPE
- Lead wire length:
- Lead wire insulation color:

**APPENDIX B
DATA SHEET****(TO BE SUBMITTED BY THE PURCHASER)****FOR****IPS-M-TP-750: Part 1****GRAPHITE ANODES**

The anodes shall be in accordance with the latest edition of above Iranian Petroleum Standard with following specific requirements:

- | | |
|-------------------------------|--------------------------------|
| - Project title: | - Date: |
| - Indent No.: | - Purchaser: |
| - M.E.S.C. No.: | |
| - Quantity: | |
| - Anode dimensions: | |
| - Anode cap type: | b Standard |
| | b Chlorine resistant |
| - Lead wire insulation type: | |
| Standard type: | b Single Jacket - HMWPE |
| | b Double Jacket - HMWPE/PVC |
| | b Double Jacket - XLPE/PVC |
| Chlorine resistant type: | b Single Jacket - PVDF |
| | b Double Jacket - XLPVDF/HMWPE |
| - Lead wire length: | |
| - Lead wire insulation color: | |

**APPENDIX C
DATA SHEET**

(TO BE SUBMITTED BY THE PURCHASER)

FOR

IPS-M-TP-750: Part 1

MAGNETITE ANODES

The anodes shall be in accordance with the latest edition of above Iranian Petroleum Standard with the following specific requirements:

- Project title:
 - Indent No.:
 - M.E.S.C. No.:
 - Quantity:
 - Anode dimensions:
 - Anode cap type:
 - b Standard
 - b Chlorine resistant
 - Lead wire insulation type:
 - Standard type:
 - b Single Jacket - HMWPE
 - b Double Jacket - HMWPE/PVC
 - b Double Jacket - XLPE/PVC
 - Chlorine resistant type:
 - b Single Jacket - PVDF
 - b Double Jacket - XLPVDF/HMWPE
 - Lead wire length:
 - Lead wire insulation color:
- Date:
 - Purchaser:

PART 2

CARBONACEOUS BACKFILL

FOR

IMPRESSED CURRENT ANODES

CONTENTS :

PAGE No.

1. SCOPE	20
2. REFERENCES	20
3. DEFINITIONS AND TERMINOLOGY	20
4. UNITS	21
5. CLASSIFICATION	21
6. REQUIREMENTS	22
7. PACKAGING FOR SHIPMENT	23
8. SAMPLING FOR INSPECTION	24
9. INSPECTION AND TESTING	24
10. LABELING	24

1. SCOPE

This Part of [IPS-M-TP-750](#) covers the minimum requirements for the supply of carbonaceous backfill for use in shallow and deep-well type impressed current ground beds.

Notes:

1) The term "carbonaceous backfill" has been used to describe the conductive backfill materials used to surround ground bed anodes to lower the total resistance of the ground bed, to improve current distribution, to prolong anode life, and to provide a permeable medium for migration of gases.

2) In case of local purchase, the specification can be tolerated to some extent.

2. REFERENCES

Throughout this Standard the following dated and undated standards/codes are referred to. These referenced documents shall, to the extent specified herein, form a part of this standard. For dated references, the edition cited applies. The applicability of changes in dated references that occur after the cited date shall be mutually agreed upon by the Company and the Vendor. For undated references, the latest edition of the referenced documents (including any supplements and amendments) applies.

ISO (INTERNATIONAL ORGANIZATION FOR STANDARDIZATION)

ISO 334	"Coal and Coke-Determination of Total Sulphur-Eschka Method"
ISO 351	"Solid Mineral Fuels-Determination of Total Sulphur-High Temperature Combustion Method"
ISO 562	"Hard Coal and Coke-Determination of Volatile Matter Content"
ISO 567	"Coke-Determination of the Bulk Density in a Small Container"
ISO 609	"Coal and Coke-Determination of Carbon and Hydrogen-High Temperature Combustion Method"
ISO 625	"Coal and Coke-Determination of Carbon and Hydrogen-Liebig Method"
ISO 687	"Coke-Determination of Moisture in the Analysis Sample"
ISO 1013	"Coke-Determination of Bulk Density in a Large Container"
ISO 1171	"Solid Mineral Fuels-Determination of Ash"
ISO 2309	"Coke-Sampling"
ISO 2325	"Coke-Size Analysis (Nominal Top Size 20 mm or Less)"

3. DEFINITIONS AND TERMINOLOGY

Ash

Inorganic residue remaining after ignition of combustible substances, determined by definite prescribed methods.

Note:

Ash may not be identical, in composition or quantity, with the inorganic substances present in the material before ignition.

Bulk density

The mass in air per unit volume of bulk material, including the voids within and between particles.

Coke

A carbonaceous solid produced from coal, petroleum, or other materials by thermal decomposition with passage through a plastic state.

Coke breeze

The fine screenings from crushed coke or from coke as taken from the ovens, of a size varied in local practice, but usually passing a 12.5 mm screen opening.

Dry screening

The screening of solid materials of different sizes without the aid of water.

Fixed carbon

In the case of coal, coke, and bituminous materials, the solid residue other than ash, obtained by destructive distillation, determined by definite prescribed methods.

Note:

It is made up principally of carbon, but may contain appreciable amounts of sulfur, hydrogen, nitrogen, and oxygen.

Screening

The separation of solid materials of different sizes by causing part to remain on a surface provided with apertures through which the remainder passes.

Sieve analysis

The process or result of the division of a sample into size fractions by the use of test sieves.

Wetting agent

A reagent to reduce the interfacial tension between a solid and a liquid and so to facilitate the spreading of the liquid over the solid surface.

Wet screening

The screening of solid materials of different sizes with the aid of water, normally in the form of a spray.

4. UNITS

This Standard is based on International System of Units (SI), except where otherwise specified.

5. CLASSIFICATION

Carbonaceous backfill material, as will be specified by the Purchaser, shall be one of the following

types:

- Type 1:** Coal coke breeze
- Type 2:** Calcined petroleum coke breeze
- Type 3:** Special calcined petroleum coke breeze

Note:

Types 1 and 2 coke breeze are to be used for shallow (horizontal or vertical) groundbeds and type 3 coke breeze for deep well groundbeds.

6. REQUIREMENTS

6.1 Composition

6.1.1 Type 1 backfill material

Backfill shall be coal coke breeze of low resistivity and low ash content. The coke breeze may be treated by the addition of 10% (by weight) of commercial grade slaked lime.

The proposed material shall have the properties of Table 1.

TABLE 1 - TYPE 1 BACKFILL MATERIAL (COAL COKE BREEZE)

PROPERTY		UNIT	REQUIREMENT	TEST METHOD
Carbon content	(min.)	wt%	80	ISO 609 or ISO 625
Moisture content	(max.)	wt%	5	ISO 687
Ash content	(max.)	wt%	15	ISO 1171
Total sulphur content	(max.)	wt%	1	ISO 351 or ISO 334
Volatile matter content	(max.)	wt%	5	ISO 562

6.1.2 Type 2 backfill material

Backfill shall be petroleum coke calcined (heat treated) to remove all other petroleum products, other than carbon, and shall be supplied in granular form. Lime in a proportion of 10% by weight of coke breeze shall be added to the product.

The proposed material shall have the properties of Table 2.

TABLE 2 - TYPE 2 BACKFILL MATERIAL (PETROLEUM COKE BREEZE)

PROPERTY		UNIT	REQUIREMENT	TEST METHOD
Carbon content	(min.)	wt%	90	ISO 609 or ISO 625
Moisture content	(max.)	wt%	5	ISO 687
Ash content	(max.)	wt%	5	ISO 1171
Total sulphur content	(max.)	wt%	5	ISO 351 or ISO 334
Volatile matter content	(max.)	wt%	5	ISO 562

6.1.3 Type 3 backfill material

Backfill shall be petroleum coke calcined (heat treated) to remove all other petroleum products, other than carbon, specially formulated to facilitate pumping, settling, and compaction of carbon lubricants. The product shall contain 0.1% wetting agent to enhance setting of the granular particles

and water absorption of the bakfill. It shall have round, uncrushable shape.

The proposed material shall have the properties of Table 3.

TABLE 3 - TYPE 3 BACKFILL MATERIAL (SPECIAL PETROLEUM COKE BREEZE)

PROPERTY	UNIT	REQUIREMENT	TEST METHOD
Carbon content (min.)	wt%	95	ISO 609 or ISO 625
Moisture content (max.)	wt%	1	ISO 687
Ash content (max.)	wt%	3	ISO 1171
Total sulphur content (max.)	wt%	1	ISO 351 or ISO 334
Volatile matter content (max.)	wt%	1	ISO 562

6.2 Bulk Density

The bulk density of backfill materials on dry packed basis shall conform to the following range:

TYPE	BULK DENSITY (kg/m ³)	TEST METHOD
1	650-800	ISO 1013 or ISO 567
2	700 - 1100	
3	1050 – 1200	

6.3 Resistivity

For Types 1 and 2 backfill material the resistivity shall be less than 100 ohm-cm when dry and lightly tamped and prior to the addition of lime. For Type 3 backfill material the resistivity of the tamped dry backfill shall not exceed 0.1 ohmcm.

6.4 Particle Size

The particle sizes of backfill materials shall conform to the following size distribution:

Type 1:	Less than 10 mm	100%
	Greater than 1 mm	90%
Type 2:	Less than 3 mm	100%
	Greater than 0.5 mm	90%
Type 3:	Less than 1.0 mm	100%
	Less than 0.6 mm	80%
	Greater than 0.4 mm	90%
	Greater than 0.15 mm	99%

The test method shall be in accordance with ISO 2325.

7. PACKAGING FOR SHIPMENT

The materials purchased according to this Standard specification shall be packaged in suitable containers to ensure acceptance and safe delivery to their destination.

The backfill shall be supplied in 25 kg bags, in 1 tone containers or other suitable containers as specified by the Purchaser.

The method of shipment, as will be specified by the Purchaser, may be either double bagged or bulk in accordance with following:

Double bagged-packaging shall be double packing in bags, the inner bag being woven polypropylene, the outer bag can be hessian but not polyethylene which is subject to U.V deterioration and temperature distortion.

Bulk-method of shipping shall be agreed upon by the Purchaser and supplier.

8. SAMPLING FOR INSPECTION

Sampling shall be in accordance with ISO 2309.

The numbers and types of test specimens shall be in accordance with the ISO test method for the specific properties to be determined.

9. INSPECTION AND TESTING

9.1 All materials supplied under this Standard specification shall be subject to timely inspection by the Purchaser or his authorized representative. The Purchaser shall have the right to reject any material(s) supplied which is (are) found to be defective under this Part of Standard specification. In case of dispute, the arbitration or settlement procedure, established in the procurement documents shall be followed.

9.2 The supplier shall be responsible for the performance and costs for all laboratory test requirements as specified in this Part of Standard specification. The supplier shall set up and maintain such quality assurance and inspection systems as are necessary to ensure that the materials comply in all respects with the requirements of this Part of Standard specification.

9.3 Purchaser's inspector(s) shall have free access to the supplier's work to follow up the progress of the materials covered by this Part of Standard specification and to check the quality of materials. The supplier shall place free of charge at the disposal of the Purchaser's inspector(s) all means necessary for carrying out their inspection results of tests, checking of conformity of materials to this Part of Standard specification, checking of marking and packing and temporary acceptance of materials.

9.4 The supplier shall furnish the Purchaser with a certified copy of results of tests made by the manufacturer covering physical and performance characteristics of each batch of product to be supplied under this Part of Standard specification. The supplier shall furnish, or allow the Purchaser to collect samples of the material representative of each batch of product. Certified test reports and samples furnished by the supplier shall be properly identified with each batch of product.

9.5 Supplier shall submit to the Purchaser a typical analysis, and the test methods used, of a random sample of backfill material giving following information:

- Moisture content.
- Carbon content.
- Ash content.
- Particle size distribution.
- Bulk density.
- Resistivity.

Supplier shall perform screening tests on samples of the backfill to ensure compliance with the particle size requirements.

10. LABELING

Each package or container of backfill material shall be marked with the following information:

Name:
Specification: [IPS-M-TP-750](#): Part 2

Order No.:
M.E.S.C No.:
Type or trade name of backfill:
Weight (gross and net):
Batch No.:
Stock No.:
Date of manufacture:
Storage conditions:
Trademark of the manufacturer:
Manufacturer's name and address:

PART 3

GALVANIC ANODES

FOR

UNDERGROUND APPLICATIONS

(MAGNESIUM AND ZINC)

CONTENTS :	PAGE No.
1. SCOPE	28
2. REFERENCES	28
3. DEFINITIONS AND TERMINOLOGY	29
4. UNITS	32
5. TECHNICAL DOCUMENTS	32
6. CLASSIFICATION	32
7. MATERIALS AND MANUFACTURE.....	32
8. REQUIREMENTS.....	35
9. CHEMICAL BACKFILL FOR GALVANIC ANODES	39
10. SAMPLING	40
11. REJECTION	40
12. INSPECTION.....	40
13. SUPPLIED DOCUMENTATION	41
14. PACKAGING AND SHIPMENT	41
15. LABELING	42
 APPENDICES:	
APPENDIX A DATA SHEET FOR MAGNESIUM ANODES.....	43
APPENDIX B DATA SHEET FOR ZINC ANODES	44
APPENDIX C METHOD FOR THE DETERMINATION OF THE ANODE-TO-CORE RESISTANCE OF GALVANIC ANODES	45

1. SCOPE

This Part of [IPS-M-TP-750](#) covers the minimum requirements for galvanic (sacrificial) anodes for use in the cathodic protection of buried structures against corrosion. It specifies the compositions, materials, manufacture, properties, inspection and testing for magnesium and zinc anodes. It also includes details of backfill compositions and properties, for magnesium and zinc anodes.

This specification covers only the general requirements for the anodes, the specific requirements will be given in pertinent ordering documents by the Purchaser (see Appendices A and B).

2. REFERENCES

Throughout this Standard the following dated and undated standards/codes are referred to. These referenced documents shall, to the extent specified herein, form a part of this standard. For dated references, the edition cited applies. The applicability of changes in dated references that occur after the cited date shall be mutually agreed upon by the Company and the Vendor. For undated references, the latest edition of the referenced documents (including any supplements and amendments) applies.

ASTM (AMERICAN SOCIETY FOR TESTING AND MATERIALS)

A 36	Standard Specification for "Structural Steel"
A 283	Standard Specification for "Low and Intermediate Tensile Strength Carbon Steel Plates"
B 6	Standard Specification for "Zinc"
B 275	Standard Practice for "Codification of Certain Nonferrous Metals and Alloys, Cast and Wrought"
B 418	Standard Specification for "Cast and Wrought Galvanic Zinc Anodes"
D 1047	Standard Specification for "Poly (Vinyl Chloride) Jacket for Wire and Cable"
D 1351	Standard Specification for "Polyethylene Insulation for Electrical Wire and Cable"
D 2219	Standard Specification for "Poly (Vinyl Chloride) Insulation for Wire and Cable"
D 2655	Standard Specification for "Crosslinked Polyethylene Insulation for Wire and Cable"
G 97	Standard Test Method for "Laboratory Evaluation of Magnesium Sacrificial Anode Test Specimens for Underground Applications"

IEC (INTERNATIONAL ELECTROTECHNICAL COMMISSION)

IEC 228	"Nominal Cross-Section Areas and Composition of Conductors of Insulated Cables"
---------	---

ISO (INTERNATIONAL ORGANIZATION FOR STANDARDIZATION)

2859-1

"Sampling Procedures for Inspection by Attributes

Part 1: Sampling Plans Indexed by Acceptable Quality Level (AQL) for Lot-by-Lot Inspection"

3. DEFINITIONS AND TERMINOLOGY

For the purpose of this Standard, the definitions below apply:

Anode backfill

Material surrounding and in contact with a buried anode to maintain or improve its performance.

Anode consumption rate

The rate of alloy mass consumption for a given current output over a given period; normally stated in kilograms per ampere year.

Anode core

A metal insert (usually steel) either cast into the anode or extruded with the anode to provide mechanical strength and attachment.

Cast sacrificial anode

The negative (reactive) component of a galvanic cell, designed to oxidize sacrificially and produce direct electrical current to protect a more electropositive (noble) metal operating in the same electrolyte and produced to a desired shape by the solidification of a molten alloy in a mold or die.

Cathodic protection

The prevention or reduction of corrosion of metal by making the metal the cathode in a galvanic or electrolytic cell.

Certificate of conformity

A statement made by the producer's representative (executive) and endorsed by a representative of the Purchaser that the anodes listed comply with the requirements of the order.

Cold lap

Horizontal discontinuity caused by solidification of the meniscus of a partially cast anode as a result of interrupted flow of the casting stream. The solidified meniscus is covered with metal when the flow resumes. Cold laps can occur along the length of an anode.

Cold shut

Horizontal surface discontinuity caused by solidification of a portion of a meniscus during the progressive filling of a mold, which is later covered with more solidifying metal as the molten metal level rises. Cold shuts generally occur at corners remote from the point of pour.

Cracking

Fracture of metal along an irregular path producing a discontinuity similar to a ragged edge. It can

occur during the solidification of the anode (hot cracking), during the contraction of the anode after solidification, or under externally applied loads. Hot cracking may be associated with the shrinkage depression the can occur in open-topped molds.

Current capacity

The total current flow available from an anode of given mass of alloy; normally expressed as ampere years per kilogram. This is the inverse of the anode consumption rate.

Current density

The average amount of current entering or leaving a given surface area.

Driving potential

The difference between the open circuit potentials of the anode and the structure.

Dulling of zinc

Deterioration in appearance of zinc-coated inserts because of oxidation that produces a white bloom of zinc oxide.

Electrochemical properties

Those properties of potential and current capacity that characterize a sacrificial anode and can be assessed by quantitative tests.

Galvanic anode

An electrode used to protect a structure by galvanic action.

Gas holes

The evidence of bubbles within the metal. The holes can indicate that moisture was on the mold or insert prior to casting, or that the liquid metal contained a high level of hydrogen that had been thrown out of solution to form bubbles during the cooling of the metal.

Gross anode mass

Total mass of an anode, including anode core, and backfill (if a packaged anode).

Heat

Also called a "melt" or "cast", it is the unit that defines molten metal and identifies the anodes cast from it. A heat is the product that is cast to a planned procedure in one melting operation in one furnace, without significant interruption. If the casting sequence is interrupted, the anodes produced before, between and after the interruptions constitute "batches".

Net anode mass

Mass of actual anode alloy.

Nonmetallic inclusions

Particles of oxides and other refractory materials entrapped in liquid metal during the melting or casting sequences.

Open circuit potential

The potential of an anode when not connected to a structure; normally measured against a reference electrode in a particular environment.

Packaged anode

Either a magnesium or zinc anode placed, with backfill, in a calico bag or other approved container to provide a uniform low resistivity environment for the anode.

Porosity

Generally distributed fine holes caused by gas bubbles, shrinkage (formed by the starvation of eutectic material within the dendrite arms during "unfed" solidification), or a combination of the two mechanisms when hydrogen in solution diffuses into the lower pressure shrinkage voids.

Protrusion

Extraneous material on the anode surface. It may interfere with the anode-to-structure fit, appear unattractive, and be a safety hazard if there are sharp edges. Protrusions can be formed by careless filling of the mold or the flash from imperfect fitting of mold sections.

Reference electrode

An electrode which has a stable potential in one or more electrolytes, thus enabling it to be used for the measurement of other electrode potentials at a given temperature.

Shrinkage depression

The natural concave surface produced when liquid metal is allowed to solidify in a container without the provision of extra liquid metal to compensate for the reduction in volume that occurs during the liquid-solid transformation. The term also applies to the concave surface produced when liquid metal is solidified in a closed mold in such a manner that the area is not "fed" by the liquid metal provided by the casting's riser.

Test anode

A prepared anode test piece, made from a test specimen by a mechanical operation.

Test sample

A portion of material or a group of items selected from a batch or consignment by a sampling procedure.

Test specimen

A portion of material or a single item taken from the test sample for the purpose of applying a particular test.

4. UNITS

This Standard is based on International System of Units (SI), except where otherwise specified.

5. TECHNICAL DOCUMENTS

The technical bid shall include the following with reference to data sheet (see Appendices A.3 and B.3).

5.1 Manufacturing drawings or catalogues for anodes: including dimensions, tolerances, steel insert grade, alloy type and weights.

5.2 Production procedures that cover all stages of the manufacturing process, from receipt of raw materials to finishing and packing for shipment, including:

- chemical analysis;
- measurements of weights, dimensions, bowing, twisting, crack size, etc.;
- backfill composition (for Type 1 anodes);
- inspection and testing procedures, and frequencies;
- anode manufacture;
- identification of rejected anodes.

5.3 Insert preparation procedures: including acceptance limits for surface, wall thinning and ovality.

5.4 Electrochemical test procedures, including acceptance criteria, description of test apparatus, measurement methods and preparation and cleaning of samples.

5.5 Preservation, packing and shipping procedures, such that anodes are not damaged or deformed and do not deteriorate during handling, delivery to the fabrication yard, storage: including methods, materials and any requirements for periodic inspections.

6. CLASSIFICATION

The anodes, as will be specified by the Purchaser (see Appendices A and B), shall be one of the following types:

- Type I:** Cast anodes.
Type II: Extruded rod (or ribbon) anodes.

7. MATERIALS AND MANUFACTURE

7.1 General

7.1.1 Anodes shall be manufactured by any suitable casting or extruding process. The anode material shall be cast or extruded around a steel insert (core) so designed as to retain the anode material even when it is consumed to its design utilization factor.

7.1.2 Manufacturing of anodes shall be carried out using approved production procedures covering each stage of the process from supply of raw materials to finishing and packing for shipment. The procedures shall be fully referenced in an Inspection and Test plan which shall also refer to requirements of this Standard specification, as applicable.

The manufacturer shall ensure that full traceability of all the materials is maintained throughout manufacture and thereafter.

7.1.3 The supplier shall submit to the Purchaser his quality assurance and control plan.

The quality control at the anode manufacturing plant shall include control systems on the following:

- Raw materials, i.e., checking of documentation.
- Production equipment and process.
- Testing during and after production.
- Identification of anodes.
- Chemical analysis.
- Weight and dimensional tolerances.
- Surface condition of produced anodes.
- Documentation (material certificates).

7.1.4 The cast anodes may be supplied bare or packaged in a permeable cloth bag containing a rapid wetting and moisture retaining backfill (see 9), which reduces the electrolyte resistivity adjacent to the anode and improves performance, as will be required by the Purchaser (see Appendices A and B).

7.2 Anode Composition

7.2.1 Magnesium anodes

Magnesium anodes shall be manufactured from virgin materials conforming to the chemical composition limits given in Table 1 as determined by approved spectrographic and analytical procedures.

The anode composition in this Standard specification meets the chemical composition requirements of ASTM specification B275 Designation M1C (also called Galvomag).

7.2.2 Zinc anodes

Zinc anodes shall be made from special High Grade Zinc conforming to ASTM specification B 6, with suitable alloying additions, with an iron content well below the 0.003% maximum given in ASTM specification B 6. Composition of the anode alloy content shall conform to the limits given in Table 2.

The anode composition in this Standard specification meets the chemical composition requirements of ASTM specification B 418, Type II.

Notes:

- 1) The chemical analysis of the anode samples may be carried out either at the time they are cast, or at the finished or semifinished product stage.**
- 2) The electrochemical properties are highly dependent on the content of alloying elements and impurity elements. The anode manufacturer shall thus prove his capability of delivering anodes which satisfy this Standard specification.**
- 3) Small deviations from the specification in the alloy composition may significantly reduce the protective properties. Generally it is of importance that the fabrication procedure ensures that the melt is not polluted by iron or other impurities. Furnaces, pumps, pipes, etc., shall be non-metallic or properly lined.**

TABLE 1 - CHEMICAL COMPOSITION LIMITS FOR MAGNESIUM ALLOY ANODES

ELEMENT		COMPOSITION, %
Aluminum,	max.	0.01
Manganese		0.9 - 1.2
Copper,	max.	0.02
Iron,	max.	0.03
Nickel,	max.	0.001
Other elements, total,	max.	0.3
Magnesium*		Remainder

* The magnesium content shall be calculated by subtracting from 100.00%.

TABLE 2 - CHEMICAL COMPOSITION LIMITS FOR ZINC ALLOY ANODES

ELEMENT		COMPOSITION, % (max.)
Aluminum		0.005
Cadmium		0.003
Iron		0.0014 ^{a)}
Lead		0.003
Copper		0.002
Other elements, total		0.012
Zinc ^{b)}		Remainder

a) Critical deleterious impurity.

b) The zinc content shall be calculated by subtracting from 100.00%.

7.3 Anode Core

7.3.1 The magnesium anode core shall be made from commercial hot dipped galvanized steel conforming to ASTM specification A 283, Grade C or equivalent standard.

7.3.2 The zinc anodes shall have steel cores conforming to ASTM specification A 36. The steel shall be coated with zinc or cadmium to a minimum thickness of 12.5 microns. Hot-dipped or electro-deposition methods may be used. Either coating shall be adherent and free from flaking. The coating shall adhere tenaciously to the surface of the base metal. When the coating is cut or pried into, such as with a stout knife applied with considerable pressure in a manner tending to remove a portion of the coating, it shall only be possible to remove small particles of the coating by paring or whittling, and it shall not be possible to peel any portion of the coating so as to expose the steel.

7.3.3 The position of the anode core shall be such that the maximum possible mass of anode material is available to provide cathodic protection.

7.3.4 Cores shall be abraded or otherwise treated to ensure that the requirements of 8.5 and 8.6 can be achieved.

7.4 Production Testing

The manufacturer shall carry out the following tests:

a) A full spectrographic analysis, or an approved alternative, of each cast. The results shall meet the requirements of Table 1 (for magnesium anodes) or Table 2 (for zinc anodes).

b) A electrochemical performance test for each cast. The test shall be carried out by the manufacturer in accordance with approved procedures designed to demonstrate batch consistency of the as cast electrochemical properties.

8. REQUIREMENTS

8.1 Performance Properties of Magnesium and Zinc Anodes

Any anode must be capable of a sufficient driving voltage to provide the necessary design current output. The performance properties of anode alloys shall be in accordance with Table 3.

TABLE 3 - PERFORMANCE PROPERTIES OF GALVANIC ANODE ALLOYS

ANODE ALLOY TYPE	OPEN CIRCUIT POTENTIAL NEGATIVE VOLTS (Cu/CuSO ₄ ELECTRODE)	CURRENT EFFICIENCY % (min)	ENERGY CAPABILITY amp-hr/kg (min)	CONSUMPTION RATE kg/amp-YEAR (max)
Zinc	1.1	90	780	11.2
Magnesium	1.7*	50	1200	7.3

* 14 days test, with reference to ASTM test method G 97.

8.2 Workmanship, Finish, and Appearance

8.2.1 The anodes shall be free of flash burrs, cracks, blow holes, and surface slag consistent with good commercial practice. The cast anodes shall be free of shrinkage cavities exceeding 6 mm (¼ inch) in depth, except that anodes 50 mm (2 inch) thick or more shall be free of shrinkage cavities exceeding 9.5 mm (3/8 inch) in depth, when measured from a straight edge placed diagonally across the opposite edges of the anode.

8.2.2 Metal core extensions from the anodes shall be smooth and free of sharp burrs. The cast-in cores shall have metallurgical bonds specified herein free of air pockets and inclusions consistent with good commercial practice.

8.2.3 The anode lead wire insulation shall be continuous having a thickness as uniform as possible and shall be completely free of nicks, scratches, or other discontinuities.

8.3 Mechanical Resistance

When an uniaxial force equivalent to 100 kg, or five times the mass of the anode metal, whichever is the greater, is applied to a cast anode containing a core, no movement of the core or any metal insert shall occur. Where a cable is provided, a uniaxial loading of 100 kg shall not result in damage to the cable or its connections.

8.4 Electrical Resistance

When determined in accordance with the test method in Appendix C, the electrical resistance of the anode to core or, if appropriate, of the anode to the end of the cable, shall be not greater than 0.01 for the life of the anode.

8.5 Anode Dimensions and Weights

8.5.1 Magnesium anodes

8.5.1.1 The cast anode (Type I) dimensions and weights (nominal), as will be specified by the Purchaser (see Appendix A), shall be as follows:



WEIGH kg (lbs)	DIMENSIONS (mm)			TOTAL PACKAGED WEIGHT (APPROX.) Kg
	A	B	C	
4.1 (9)	90	90	350	10
7.7 (17)	90	90	650	20
14.5 (32)	140	140	540	30
21.8 (48)	140	140	820	45

Core straps shall be 20 gage (8 mm) perforated electroplate galvanize steel with 6 mm. holes on 12.7 mm (½ inch) centers. The core length shall be 75% of anode length.

8.5.1.2 The Type II anodes dimensions and weight (nominal) shall be as follows:

- Magnesium weight: 370 g/m
- Cross section: 9.5 × 19 mm
- Core diameter: 3.2 mm
- Coil length: 300 m (unless otherwise specified by the Purchaser),
(see Appendix A).

8.5.2 Zinc anodes

8.5.2.1 The cast anode (Type I) dimensions and weights (nominal), as will be specified by the Purchaser (see Appendix B), shall be as follows:

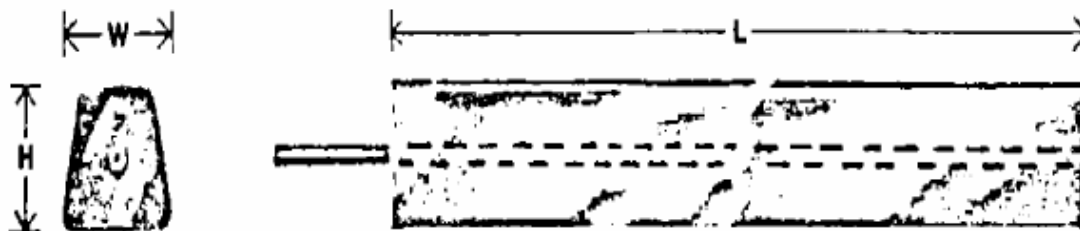

WEIGH kg (lbs)	DIMENSIONS (mm)		
	W	H	L
2.3 (5)	35	35	230
5.5 (12)	35	35	610
8.2 (18)	35	35	915
13.6 (30)	50	50	760
20.5 (45)	50	50	1140
27.3 (60)	50	50	1525

The cores shall be made of a 6.35 mm (¼ inch) diameter electrogalvanized mild steel.

8.5.2.2 The Type II anode dimensions and weights (nominal), as will be specified by the Purchaser (see Appendix B), shall be as follows:

WEIGH kg/m (lb/ft)	CROSS SECTION (mm)	COIL LENGTH* (m)
1.8 (1.2)	15.8×22.2	60
0.9 (0.6)	12.7 × 14.2	150
0.37 (0.25)	8.7 × 11.9	300

* Unless otherwise specified by the Purchaser (see Appendix B.3).

8.5.3 Dimensions and weights tolerances shall conform to the following:

8.5.3.1 Anode mean length shall not deviate more than 3% of nominal length.

8.5.3.2 Anode mean width shall not deviate more than 3% of nominal width.

8.5.3.3 The straightness of the anode shall not deviate more than 2% of the anode nominal length from the longitudinal axis of the anode.

8.5.3.4 The permissible variation in weight of each finished anode will be plus or minus 5% of the nominal weight.

8.5.3.5 The total contract weight shall be no more than 2% above and not below the nominal contract weight.

8.6 Methods of Attachment of Cable for Cast Anodes

8.6.1 The cast anodes shall be supplied complete with cables connected to the anode core. One end of the anode shall be recessed to provide cavity for attachment of the lead wire to the anode core and subsequent sealing of this connection.

The method of connecting the lead wire to anode core shall be either by the use of a brazed connection or silver solder connection or any other approved method. The connection shall be so to bear the weight of the anode.

The lead wire to anode core connection shall be sealed to prevent water intrusion by application of a potting compound (e.g., epoxy resin) or mastic-lined polyethylene heat-shrink sleeve to completely seal the connection and to protect the joint mechanically.

For Magnesium anodes, typical methods of attachment are shown in Figs. 1 and 2.

For zinc anodes, a typical method of attachment is shown in Fig. 2.

8.6.2 The lead wires shall be 6 sq. mm single core, stranded soft annealed copper conductor conforming to IEC Publication 228, Class 2 or ASTM specification B 8 Class B, and 5 meter in length.

8.6.3 The lead wire insulation, as will be specified by the Purchaser (see Appendices A and B) shall be in accordance with one of the following alternatives:

- A single jacket of High Molecular Weight Polyethylene (HMWPE) insulation conforming to ASTM specification D 1351, having a minimum thickness of 1.5 mm.
- A single jacket of Cross-Linked Polyethylene (XLPE) insulation conforming to ASTM specification D 2655, having a minimum thickness of 1 mm.
- A double jacket of Polyvinyl Chloride (PVC) primary insulation conforming to ASTM specification D 2219, sheathed with a polyvinyl chloride jacket conforming to ASTM specification D 1047. The average insulation (of insulation and sheath), shall be 2 mm with a 10% tolerance.

8.6.4 Lead wire insulation shall have a minimum of 600 Volt rating.

8.6.5 The color of the insulation of anode cables should be red, unless otherwise specified by the Purchaser.

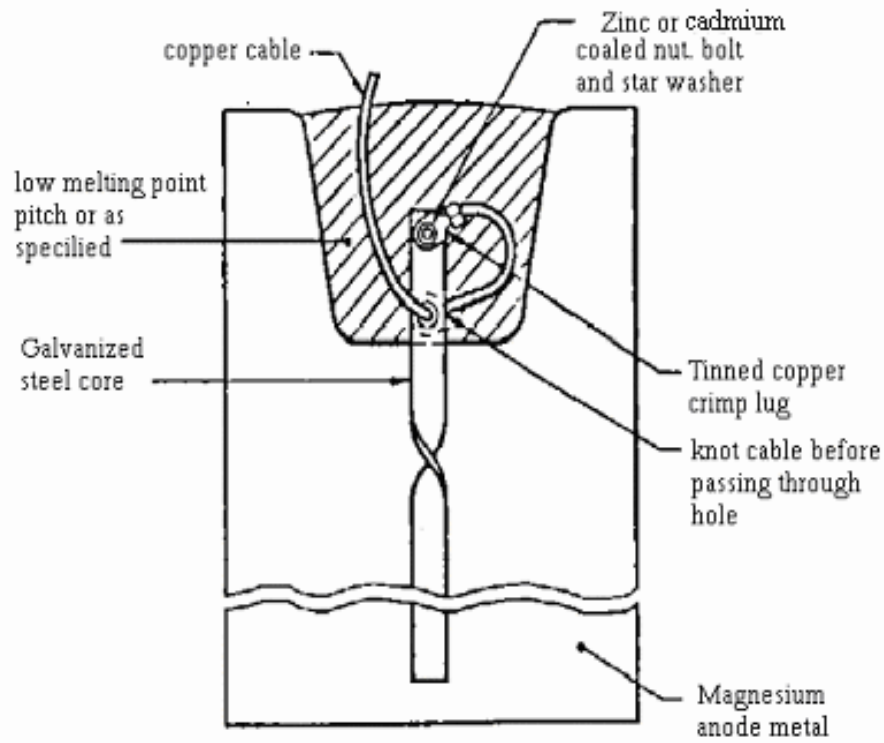

TYPICAL METHOD OF CABLE ATTACHMENT FOR BURIED MAGNESIUM ANODES

Fig. 1

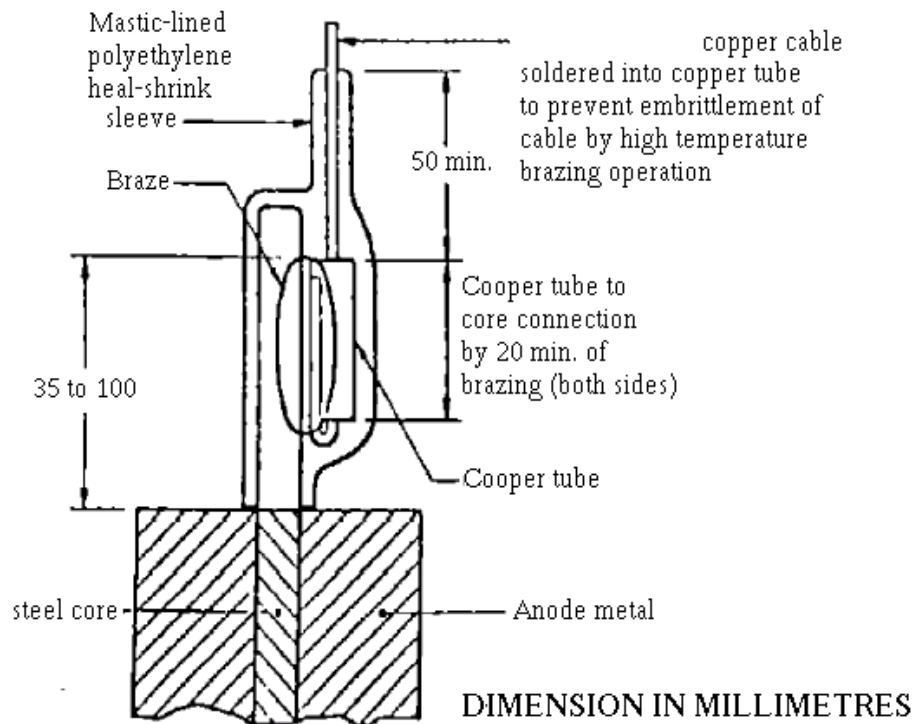

TYPICAL METHOD OF CABLE ATTACHMENT FOR BURIED ANODES

Fig. 2

8.7 Identification of Anodes

Each anode shall be clearly marked with the type of material (trade name), the cast number, and a piece serial number. The numbers of any rejected anodes shall not be used again for replacement anodes.

9. CHEMICAL BACKFILL FOR GALVANIC ANODES

9.1 Backfill Composition

When specified by the Purchaser, the cast anodes shall be supplied with backfill. The backfill surrounds, as will be specified by the Purchaser, with reference to notes to Table 4 shall be in accordance with one of the nominal composition of Table 4 (see data sheet).

TABLE 4 - BACKFILL COMPOSITION

GYPSUM (CaSO4)%		Bentonite Clay %	Sodium Sulfate %	Approx. Resistivity in Ohm-cm
Hydrated	Molding Plaster (Plaster of Paris)			
(A) 25	---	75	---	250
(B) 50	---	50	---	250
(C) ---	50	50	---	250
(D) 75	---	20	5	50

Notes:

- 1) Backfill mix (A), is useful in low soil moisture areas and utilizes the moisture-holding characteristic of the bentonite clay.**
- 2) Backfill mix (B), is commonly used with Zinc anodes.**
- 3) Backfill mix (C), is useful with Zinc or Magnesium in very wet or marshy soils to prevent rapid migration of backfill from anode surface.**
- 4) Backfill mix (D), with low resistivity, is useful in high soil resistivity areas to reduce the anode resistance to earth.**

9.2 Particle Size

The Backfill shall have a grain size so that 100% is capable of passing through a 0.84 mm. (20 mesh screen) and 50% shall be retained by a 0.15 mm (100 mesh screen), and shall contain not more than 5% moisture.

9.3 Backfill Analysis

The manufacturer shall submit to the Purchaser a typical analysis of a random sample of backfill material giving the following information:

- Moisture content.
- Gypsum content.
- Bentonite content.
- Sodium sulfate content (if any).

The manufacturer shall perform screening tests on samples of the backfill to ensure backfill is in the form of a fine powder.

9.4 Anode Packaging

Anodes shall be packed in a calico bag, or in some other type of approved porous container. The diameter of the packaging shall be at least 50 mm greater than the diagonal of the anode. The backfill shall be tightly packed in the bag to prevent movement of the anode and shall achieve the following coverage around the anode:

- a) A minimum of 25 mm of cover on corners, measured diagonally.
- b) A minimum of 50 mm of cover on the top, bottom and sides.

The backfill shall be firmly held around the anode, the whole shall be vibrated during filling to ensure compaction.

The container shall be sealed to minimize moisture intrusion during storage and shipment and to ensure against loosening or loss of backfill.

10. SAMPLING

10.1 Lot

Unless otherwise specified by the Purchaser, a lot shall consist of all anodes made from the same production run offered for inspection at one time.

10.2 Sampling for Inspection

Sample anodes shall be selected from each lot in accordance with inspection level II of ISO 2859 (Part 1). The Acceptable Quality Level shall be 4 percent for all visual, dimensional and weight defects combined and 2.5 percent for all other type of defects with reference to this Part of Standard specification. The single sampling plans for normal inspection (Table IIA of ISO 2859 (Part 1)) shall be used.

11. REJECTION

Where the numbers of anodes that do not conform to this Part of Standard specification exceed the acceptance numbers specified in 10.2, this shall be cause for rejection of entire lot.

12. INSPECTION

12.1 Responsibility for Inspection

12.1.1 The manufacturer and/or supplier shall be responsible for carrying out all the tests and inspections (during and after fabrication) required by this Part of Standard specification, using his own or other reliable facilities, and he shall maintain complete records of all such tests and inspections. Such records shall be available for review by the Purchaser.

12.1.2 The manufacturer and/or supplier shall afford the purchaser's inspector all reasonable facilities necessary to satisfy him that the material is being produced and furnished in accordance with this Part of Standard specification. Such inspections in no way relieve the manufacturer and/or supplier of his responsibility under the terms of this Standard specification.

12.1.3 The Purchaser reserves the right to perform any inspections set forth in this Part of Standard specification where such inspections are deemed necessary to assure that supplies and services

conform to the prescribed requirements.

12.1.4 The purchaser's inspector shall have access to the material subject to inspection for the purpose of witnessing the selection of the samples, the preparation of the test samples, and the performance of the tests. For such tests, the inspector shall have the right to indicate the pieces from which the samples will be taken in accordance with the provisions of this Part of Standard specification.

12.2 Inspection

Inspection shall cover the following as a minimum:

- a)** Dimensional checking, identification, weight, and quality of casting on at least 5% of the number of anodes from each cast.
- b)** Quality of steel inserts (cores) before casting on at least 5% of inserts for the batch of anodes from each cast. Any reject inserts shall be isolated and returned to the fabricator or the electroplater for correction.
- c)** Quality of insulation of the anode lead wire and each anode lead to anode seal connection to ensure absence of holes or nicks or other faults.
- d)** Compliance of prepackaged anodes with Clause 9.4 particularly with respect to centering of the anode in the backfill.
- e)** Inspection of results of spectro analysis, electrochemical tests, and other tests required by this Part of Standard specification.

13. SUPPLIED DOCUMENTATION

The following documentation shall be supplied with each anode batch:

- Certificate No. and date.
- The anode type, batch, cast and heat numbers.
- Details of anode casting, weights (net and gross) and numbers.
- Results of any destructive testing.
- Results of any non-destructive testing.
- Electrochemical test results.
- Anode alloy chemical analysis methods and results.
- Backfill composition analysis results (if any).
- Material specification and trade name.
- The anode manufacturer.
- The company's order No.
- The date of manufacture.
- Certificate of conformity with this Part of Standard specification.

14. PACKAGING AND SHIPMENT

14.1 Anodes shall be bundled, strapped, placed on pallets, or in sturdy crates with supports, pads, and binding as necessary to facilitate unloading and minimize damage to anodes during shipment, multiple rough handling, and intransit storage.

14.2 Leads shall be carefully coiled and positioned inside the crate or on the pallet as necessary to minimize damage during loading and transportation.

14.3 Cleaning, preservation, and packaging of anodes shall be in accordance with the manufacturer's commercial practice, provided they are such as to ensure acceptance by common or other carriers for safe transportation to the delivery point.

14.4 The prepackaged anodes shall be contained in a waterproof bag clearly marked "outer bag to be removed before installation".

Note:

For backfill-surrounded anodes, the total contents are normally contained within the packaging, should the Purchaser require special packaging or limitations on the mass of such packages, such requirements shall be specified.

15. LABELING

15.1 Marking of Anodes

The following information shall be legibly and durably marked on each anode or group of anodes supplied, or on a label securely fixed to each anode:

- a) The name or registered mark of the manufacturer or supplier.
- b) The alloy designation.
- c) Nominal net mass of the anode and, in the case of a packaged anode, the gross mass of the anode and the backfill.

Note:

Gross mass also includes the mass of the cable attached to the anode.

- d) If appropriate, the instruction "remove plastic bag prior to installation of the anode".
- e) The backfill composition (if any).
- f) Batch number.
- g) Cast number.

The anode lead wire shall be identified by surface marking indicating manufacturer's identification, conductor size, voltage rating and insulation type.

15.2 Marking of Container

Each pallet shall be plainly marked with the following information:

- Name:
- Specification: [IPS-M-TP-750](#): Part 3
- Order No.:
- M.E.S.C No.:
- Anode type:
- Anode weight (net and gross):
- Anode dimensions:
- Batch No.:
- Stock No.:
- Date of manufacture:
- Quantity:
- Manufacturer's name and address:

Note:

Each pallet shall be clearly marked "FRAGILE".

APPENDICES**APPENDIX A
DATA SHEET****(TO BE SUBMITTED BY THE PURCHASER)****FOR****IPS-M-TP-750: Part 3****MAGNESIUM ANODES**

The anodes shall be in accordance with the latest edition of above Iranian Petroleum Standard with following specific requirements:

- Project title: - Date:
- Indent No.: - Purchaser:
- M.E.S.C. No.:

Type I Anodes:

- Quantity: Nos.
- Weight of Magnesium:kg
- Lead wire insulation type:
 - b Single Jacket - HMWPE
 - b Single Jacket - XLPE
 - b Double Jacket - PVC/PVC
- Backfill mixture:

Type II Anodes:

- Quantity (Coil length):m

**APPENDIX B
DATA SHEET****(TO BE SUBMITTED BY THE PURCHASER)****FOR****IPS-M-TP-750: Part 3****ZINC ANODES**

The anodes shall be in accordance with the latest edition of above Iranian Petroleum Standard with following specific requirements:

- Project title: - Date:
- Indent No.: - Purchaser:
- M.E.S.C. No.:

Type I Anodes:

- Quantity: Nos.
- Weight of Anode (Net): kg
- Lead wire insulation:
 - b Single Jacket - HMWPE
 - b Single Jacket - XLPE
 - b Double Jacket - PVC/PVC
- Anode Packaging:
 - b Packaged with backfill in Calico bag
 - b Bare anode (No backfill)
- Backfill mixture:

Type II Anodes:

- Zinc Weight (kg/m):
- Quantity: m

APPENDIX C
METHOD FOR THE DETERMINATION OF THE ANODE-TO-CORE
RESISTANCE OF GALVANIC ANODES

C.1 General

This Appendix describes the method for the determination of the anode-to-core resistance of galvanic (sacrificial) anodes used for cathodic protection.

C.2 Principle

The voltage across the anode metal and anode core is measured when a known current is passed between them. The anode-to-core resistance is then computed by dividing the measured voltage by the known current.

C.3 Apparatus

The following apparatus is required:

- a) A d.c. supply of 5 A capacity, with an adjustable current control capable of smooth variation from 5 A to near zero. It shall be capable of generating an on-load-voltage sufficient to pass a current of 5 A through a resistance of not less than 1 Ω .
- b) An ammeter capable of reading to at least 5A d.c. with a maximum error of $\pm 1\%$ at full scale deflection. This ammeter may be integral with the d.c. supply (see Item (a)).
- c) A millivoltmeter of the electrically protected type capable of reading to 50 mV d.c., with a maximum error of $\pm 1\%$.
- d) Suitable test leads and clamps or clips to connect Items (a), (b) and (c) to the anode and the core. The clamp system shall be of such quality to ensure that the connection resistance to each point is less than 0.05 Ω .

C.4 Circuit

The circuit shall be arranged as shown in Fig. C.1 (a) or (b), as applicable. The leads connecting the millivoltmeter to the anode and the anode core (or cable), shall be independent of the leads from the power supply. All connections shall be properly made to minimize contact resistance.

If the millivoltmeter is connected across the anode metal and the terminal of the cable attached to the anode core, the anode-to-core resistance is obtained by subtracting the cable resistance from the total resistance. The total resistance is computed by dividing the measured potential by the known current.

C.5 Procedure

The procedure shall be as follows:

- a) Before connecting the power supply, set the variable current control to ensure a minimum current flow when the circuit is switched on.
- b) Connect the power supply. Adjust the variable current control until approximately 5 A is registered on the ammeter.
- c) Read the voltage difference as indicated by the millivoltmeter.

(to be continued)

APPENDIX C (continued)

d) Calculate the anode-to-core resistance (R), in ohms, using the following equation:

$$R = \frac{\text{millivoltmeter reading (in volts)}}{\text{ammeter reading (in amperes)}}$$

e) Reverse both ammeter supply leads and also the millivoltmeter supply leads, and repeat Steps (a) to (d) above. The results of this second calculation of R should be the same as the initial result.

C.6 Report

The test report shall contain the following information:

- a)** Name of test laboratory.
- b)** Identification of the equipment used to carry out the test.
- c)** Identification of the galvanic anode tested
- d)** The date on which the test was carried out.
- e)** The results of the anode-to-core resistance test calculations.
- f)** Reference to this test method.

(to be continued)

APPENDIX C (continued)

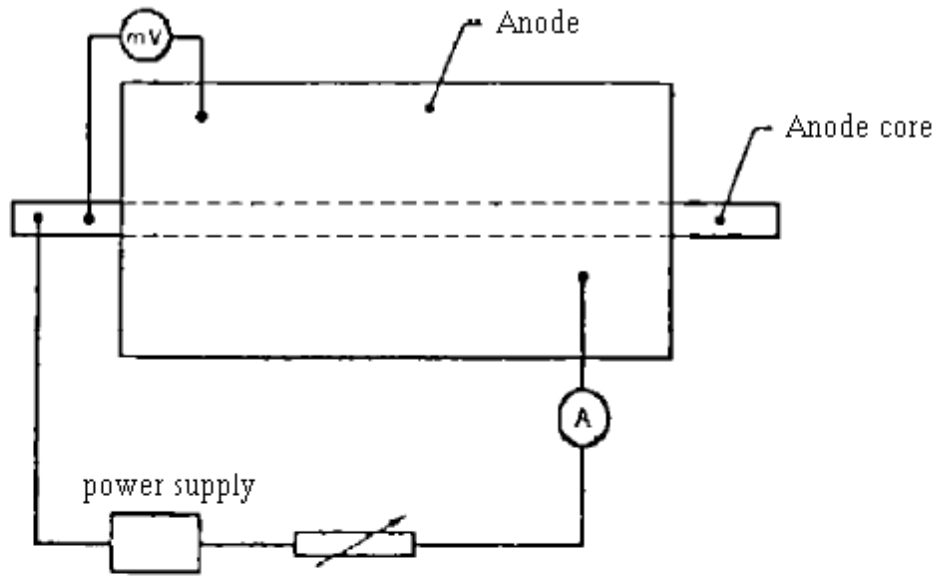

a) Without cable attached

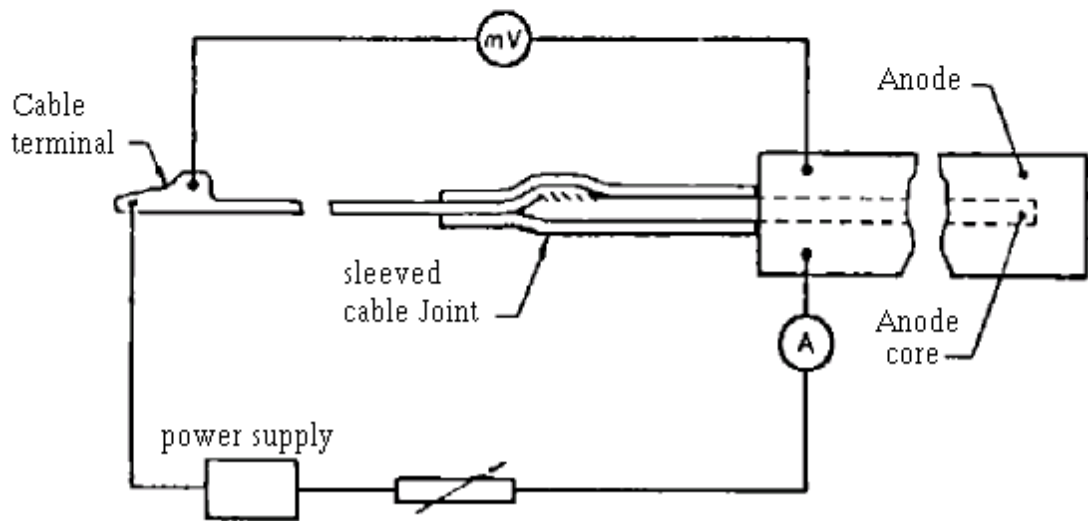

b) With cable attached

SCHEMATIC CIRCUITS FOR MEASUREMENT OF ANODE-TO-CORE RESISTANCE

Fig. C.1

PART 4

GALVANIC ANODES

FOR

SUBMERGED APPLICATIONS

(MAGNESIUM AND ZINC)

CONTENTS :	PAGE No.
1. SCOPE	50
2. REFERENCES	50
3. UNITS	50
4. TECHNICAL DOCUMENTS	50
5. MATERIALS AND MANUFACTURE	51
6. REQUIREMENTS	52
7. INSPECTION	52
8. ACCEPTANCE/REJECTION	52
9. ORDERING INFORMATION	53
10. SUPPLIED DOCUMENTATION	53
11. MARKING OF CONTAINERS	53
 APPENDICES:	
APPENDIX A DATA SHEET FOR ZINC ALLOY ANODES	54
APPENDIX B DATA SHEET FOR MAGNESIUM ALLOY ANODES	55
APPENDIX C METHOD FOR THE DETERMINATION OF THE ANODE-TO-CORE RESISTANCE OF GALVANIC ANODES	56

1. SCOPE

1.1 This Part of [IPS-M-TP-750](#) covers the minimum requirements for supply, identification, inspection and testing of galvanic (sacrificial) anodes made of Magnesium or Zinc.

1.2 The magnesium alloy anodes conforming to this Part of Standard specification are intended for use in corrosion protection in sea water or under water surfaces of ships, vented ballast tanks of oilers, piers and dock structures, and other underwater (submerged) metallic structures. Galvanized steel structures may also be protected.

1.3 The zinc alloy anodes conforming to this Part of Standard specification are intended for use in corrosion prevention in sea water of ship hulls, steel and aluminum equipments and structures, sea chests, sonar domes and the sea water side of condensers and other heat exchangers.

2. REFERENCES

Throughout this Standard the following dated and undated standards/codes are referred to. These referenced documents shall, to the extent specified herein, form a part of this standard. For dated references, the edition cited applies. The applicability of changes in dated references that occur after the cited date shall be mutually agreed upon by the Company and the Vendor. For undated references, the latest edition of the referenced documents (including any supplements and amendments) applies.

ASTM (AMERICAN SOCIETY FOR TESTING AND MATERIALS)

A 106	"Specification for Seamless Carbon Steel Pipe for High-Temperature Service"
A 185	"Specification for Steel Welded Wire, Fabric, Plain, for Concrete Reinforcement"

BSI (BRITISH STANDARDS INSTITUTION)

BS 1501	"Steels for Pressure Purposes: Plates"
BS 3602	"Specification for Steel Pipes and Tubes for Pressure Purposes: Carbon and Carbon Manganese Steel with Specified Elevated Temperature Properties"

ISO (INTERNATIONAL ORGANIZATION FOR STANDARDIZATION)

ISO 8501-1	"Preparation of Steel Structures Before Application of Paints and Related Products-Visual Assessment of Surface Cleanliness"
------------	--

3. UNITS

This Standard is based on International System of Units (SI), except where otherwise specified.

4. TECHNICAL DOCUMENTS

The technical bid shall include the following:

4.1 Manufacturing drawings or catalogues for offered anodes: including dimensions, tolerances, steel insert grade, alloy type and weights.

4.2 Production procedures that cover all stages of the manufacturing process, from receipt of raw materials to finishing and packing for shipment, including:

- chemical analysis;
- surface preparation;
- measurements of weights, dimensions, bowing, twisting, crack size, etc.;
- inspection and testing procedures, and frequencies;
- anode manufacture;
- identification of rejected anodes.

4.3 Insert bending, welding and preparation procedures: including acceptance limits for wall thinning and ovality, nondestructive testing procedures, surface profile measurements.

4.4 Electrochemical test procedures, including acceptance criteria, description of test apparatus, measurement methods and preparation and cleaning of samples.

4.5 Preservation, packing and shipping procedures, such that anodes are not damaged or deformed and do not deteriorate during handling, delivery to the fabrication yard, storage: including methods, materials and any requirement for periodic inspections.

5. MATERIALS AND MANUFACTURE

5.1 General

5.1.1 The electrochemical properties are highly dependent on the content of alloying elements and impurity elements. The anode manufacturer shall thus prove his capability of delivering anodes which satisfy this Part of Standard specification.

5.1.2 Small deviations from the specification in the alloy composition may significantly reduce the protective properties. Generally it is of importance that the fabrication procedure ensures that the melt is not polluted by iron or other impurities. Furnaces, pumps, pipes, etc., shall be non-metallic or properly lined.

5.1.3 The quality control at the anode manufacturing plant shall include control systems on the following:

- Raw materials, i.e., checking of documentation.
- Production equipment and process.
- Testing during and after production.
- Identification of anodes.
- Chemical analysis.
- Weight and dimensional tolerances.
- Surface condition of produced anodes.
- Documentation (material certificates).

5.1.4 The manufacturer shall submit the Purchaser his quality assurance and control plan.

5.2 Magnesium Anodes

The Magnesium anodes shall meet the requirements of US Military Specification MIL-A-21412A (ships), unless specified otherwise by this Part of Standard specification.

5.3 Zinc Anodes

The zinc anodes shall meet the requirements of US Military Specification MIL-A-18001 H, unless specified otherwise by this Part of Standard specification.

5.4 Production Testing

The manufacturer shall carry out the following tests:

5.4.1 A full spectrographic analysis of each cast. The results shall meet the requirements of US Military specification MIL-A-21412A (for magnesium anodes) or MIL-A-18001 H (for zinc anodes).

5.4.2 A short-term voltage test for zinc anodes only. Duration of test 3 hours minimum, current density 0.75 mA/cm², in sea water (natural or synthetic) of 20°C.

Anode potential (active) to be minus 1000 mv (saturated calomel) or more negative. Anode potential (at rest) to be minus 1050 mv (saturated calomel). The test shall be carried out for each cast.

5.4.3 A destructive testing of one anode of each anode type/design, where net weight of the anode exceeds 100 kg, to check the bonding between anode material and steel core in cross-sectional areas.

The anode material shall be bonded to the steel core over a minimum of 90% of the total surface, while no individual discontinuity or void in the bonding shall exceed 25 mm in length.

6. REQUIREMENTS

6.1 Quality of Anode Castings

6.1.1 The as-cast anode surface shall be free of surface slag or other embedded material.

6.1.2 Cracks are not acceptable, except in the form of micro (hairline) cooling cracks. Maximum width 1 mm.

6.1.3 Shrinkage cavities shall not exceed 10 mm in depth, as taken from the anode surface. Slag inclusions are not acceptable.

Tolerance on the dimensions of anodes, position of anode inserts and gross weight of anodes, to be plus and minus 2%.

6.2 Quality of Steel Inserts

Any type of steel core, insert, or bracket shall be fabricated from fully-killed low-carbon steel, pipe material to be ASTM A 106 Gr. B or BS 3602-HFS27, and plate/strip to be ASTM A 185 Grade C or BS 1501-151 Gr. 26A, to be substantiated by mill certificates.

Steel cores and inserts shall be blast-cleaned to Grade Sa 2½ according to ISO 8501-1, and have this finish at the time of casting.

6.3 Electrical Resistance

When determined in accordance with the test method in Appendix C, the electrical resistance of the anode to core or, if appropriate, of the anode to the end of the cable, shall be not greater than 0.01 Ω for the life of the anode.

6.4 Identification of Anodes

Each anode shall be clearly marked with the type of material (trade name), the cast number, and a piece serial number. The numbers of any rejected anodes shall not be used again for replacement anodes.

7. INSPECTION

Inspection shall cover the following as a minimum:

- a) Dimensional checking, identification, weight, and quality of castings on at least 5% of the number of anodes from each cast.
- b) Quality of steel inserts before casting, and surface preparation on at least 5% of inserts for the batch of anodes from each cast.
- c) Quality of steel-anode bonding on the anode from each order, selected for destructive testing.
- d) Inspection of results of spectro analysis, voltage tests, and capacity tests, done by manufacturer.
- e) After transport to installation site, a final visual check to be carried out to ensure that anodes have not been damaged during transport and handling.

8. ACCEPTANCE/REJECTION

Acceptance/rejection of anodes will be on a total inspection of all anodes.

Where any of the requirements, mentioned in this Part of Standard specification, are not met, the anodes and the relevant batch of anodes will be rejected.

9. ORDERING INFORMATION

(See Appendices A and B).

10. SUPPLIED DOCUMENTATION

The following documentation shall be supplied with each anode batch:

- Certificate No. and date.
- Designation of product.
- The anode batch and cast numbers.
- Details of anode casting weights (net and gross) and numbers.
- Steel core mill certification.
- Results of any destructive testing.
- Results of any non-destructive testing.
- Electrochemical test results.
- Anode alloy chemical analysis results.
- Material specification and trade name.
- The anode manufacturer.
- The Company's order and project name.
- The date of manufacture.

11. MARKING OF CONTAINERS

Each pallet shall be plainly marked with the following information:

- Name:
- Specification: [IPS-M-TP-750](#): Part 4
- Order No.:
- M.E.S.C No.:
- Anode class, type and style:
- Anode weight (net and gross):
- Anode dimensions:
- Batch No.:
- Stock No.:
- Date of manufacture:
- Quantity:
- Manufacturer's name and address:

Note:

Each pallet shall be clearly marked "FRAGILE".

APPENDICES**APPENDIX A
DATA SHEET****(TO BE SUBMITTED BY THE PURCHASER)****FOR****IPS-M-TP-750: Part 4****ZINC ALLOY ANODES**

The anodes shall be in accordance with the latest edition of above Iranian Petroleum Standard with the following specific requirements:

- Project title:
- Date:
- Indent No.:
- Purchaser:.....
- M.E.S.C. No.:
- No. of Anodes:
- Anode Classification (for selection see MIL-A-18001 H, Classification).

b Class 1:

b Type ZHS :	Length:	Width:	Thickness:
b Type ZHB:			
b Type ZHC:	Length:	Width:	Thickness:
b Type ZSS			
b Type ZTS			
b Type ZEP:		b Style A	
		b Style B	Diameter:
		b Style C	
b Type ZBP			
b Type ZDM		Diameter:	

b Class 2:

b Type ZRN:	Pipe or Bolt Diameter:
-------------	------------------------

- Packing requirements (other than those required by MIL-A-18001 H, preparation for delivery):

**APPENDIX B
DATA SHEET**

(TO BE SUBMITTED BY THE PURCHASER)
FOR

IPS-M-TP-750: Part 4 MAGNESIUM ALLOY ANODES

The anodes shall be in accordance with the latest edition of above Iranian Petroleum Standard with the following specific requirements:

- Project title: - Date:
- Indent No.: - Purchaser:.....
- M.E.S.C. No.: - No. of Anodes:
- Anode Classification (for selection see MIL-A-21412 A, Classification).

Class: Type: Style:

- Anode Shape (for types MOP-50 and MOB-50 anodes, if technical requirements so dictates):

b "D" b Round b Square

- Packing requirements (other than those required by MIL-A-21412 A, preparation for delivery):

APPENDIX C
METHOD FOR THE DETERMINATION OF THE ANODE-TO-CORE
RESISTANCE OF GALVANIC ANODES

C.1 General

This Appendix describes the method for the determination of the anode-to-core resistance of galvanic (sacrificial) anodes used for cathodic protection.

C.2 Principle

The voltage across the anode metal and anode core is measured when a known current is passed between them. The anode-to-core resistance is then computed by dividing the measured voltage by the known current.

C.3 Apparatus

The following apparatus is required:

- a) A d.c. supply of 5 A capacity, with an adjustable current control capable of smooth variation from 5 A to near zero. It shall be capable of generating an on-load-voltage sufficient to pass a current of 5 A through a resistance of not less than 1 Ω .
- b) An ammeter capable of reading to at least 5 A d.c. with a maximum error of $\pm 1\%$ at full scale deflection. This ammeter may be integral with the d.c. supply (see Item (a)).
- c) A millivoltmeter of the electrically protected type capable of reading to 50 mV d.c., with a maximum error of $\pm 1\%$.
- d) Suitable test leads and clamps or clips to connect Items (a), (b) and (c) to the anode and the core. The clamp system shall be of such quality to ensure that the connection resistance to each point is less than 0.05 Ω .

C.4 Circuit

The circuit shall be arranged as shown in Fig. C.1. The leads connecting the millivoltmeter to the anode and the anode core. Shall be independent of the leads from the power supply. All connections shall be properly made to minimize contact resistance.

If the millivoltmeter is connected across the anode metal and the terminal of the cable attached to the anode core, the anode-to-core resistance is obtained by subtracting the cable resistance from the total resistance. The total resistance is computed by dividing the measured potential by the known current.

C.5 Procedure

The procedure shall be as follows:

- a) Before connecting the power supply, set the variable current control to ensure a minimum current flow when the circuit is switched on.
- b) Connect the power supply. Adjust the variable current control until approximately 5A is registered on the ammeter.
- c) Read the voltage difference as indicated by the millivoltmeter.

(to be continued)

APPENDIX C (continued)

d) Calculate the anode-to-core resistance (R), in ohms, using the following equation:

$$R = \frac{\text{millivoltmeter reading (in volts)}}{\text{ammeter reading (in amperes)}}$$

e) Reverse both ammeter supply leads and also the millivoltmeter supply leads, and repeat Steps (a) to (d) above. The result of this second calculation of R should be the same as the initial result.

C.6 Report

The test report shall contain the following information:

- a) Name of test laboratory.
- b) Identification of the equipment used to carry out the test.
- c) Identification of the galvanic anode tested.
- d) The date on which the test was carried out.
- e) The results of the anode-to-core resistance test calculations.
- f) Reference to this test method.

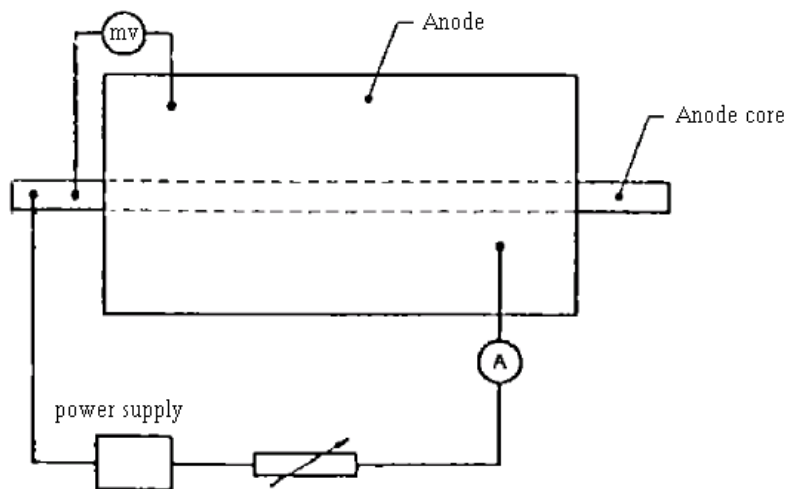

SCHEMATIC CIRCUITS FOR MEASUREMENT OF ANODE-TO-CORE RESISTANCE

Fig. C.1

PART 5

BRACELET TYPE GALVANIC ANODES

FOR

SUBMARINE PIPELINES

(ALUMINUM AND ZINC)

CONTENTS :	PAGE No.
1. SCOPE	60
2. REFERENCES	60
3. DEFINITIONS AND TERMINOLOGY	60
4. UNITS	63
5. TECHNICAL DOCUMENTS	63
6. MATERIALS AND MANUFACTURE	64
7. ANODE CORE STEEL WORKS	67
8. REQUIREMENTS	68
9. INSPECTION	70
10. ACCEPTANCE/REJECTION	71
11. SUPPLIED DOCUMENTATION	71
12. ORDERING INFORMATION	71
13. PACKING AND SHIPMENT	71
14. LABELING	72
 APPENDICES:	
APPENDIX A METHOD FOR THE DETERMINATION OF THE ANODE-TO-CORE	73
RESISTANCE OF GALVANIC ANODES	73
APPENDIX B METHOD FOR THE DETERMINATION OF THE CONSUMPTION RATE OF ALUMINUM ANODE ALLOYS IMMERSERD IN SEAWATER	76
APPENDIX C METHOD FOR THE DETERMINATION OF THE CLOSED-CIRCUIT_POTENTIAL OF ALUMINUM ANODES IMMERSERD IN SEAWATER	79
APPENDIX D DATA SHEET_FOR BRACELET GALVANIC ANODES	81

1. SCOPE

This Part of [IPS-M-TP-750](#) covers the minimum requirements for the material, manufacture, inspection and testing, documentation, and supply of half-shell bracelet type galvanic anodes made of Aluminum and/or Zinc, to be used for the cathodic protection of submarine pipelines.

2. REFERENCES

Throughout this Standard the following dated and undated standards/codes are referred to. These referenced documents shall, to the extent specified herein, form a part of this standard. For dated references, the edition cited applies. The applicability of changes in dated references that occur after the cited date shall be mutually agreed upon by the Company and the Vendor. For undated references, the latest edition of the referenced documents (including any supplements and amendments) applies.

ASTM (AMERICAN SOCIETY FOR TESTING AND MATERIALS)

B6	Standard Specification for "Zinc"
B418	Standard Specification for "Cast and Wrought Galvanic Zinc Anodes"
D1141	Standard Specification for "Substitute Ocean Water"

AWS (AMERICAN WELDING SOCIETY)

D1.1	"Structural Steel Welding Code"
------	---------------------------------

BSI (BRITISH STANDARDS INSTITUTION)

EN 10025	"Hot Rolled Products on Non-alloy Structural Steels and Their Technical Delivery Conditions"
BS 729	"Hot Dip Galvanized Coatings on Iron and Steel Articles"
BS EN 12329	"Corrosion Protection of metals Electrodeposited Coating of Zinc with Supplementary Treatment on Iron or Steel"

ISO (INTERNATIONAL ORGANIZATION FOR STANDARDIZATION)

8501-1	"Preparation of Steel Substrates before Application of Paints and Related Products-Visual Assessment of Surface Cleanliness"
--------	--

3. DEFINITIONS AND TERMINOLOGY

Anode consumption rate

The rate of alloy mass consumption for a given current output over a given period; normally stated in kilograms per ampere year.

Cast sacrificial anode

The negative (reactive) component of a galvanic cell, designed to oxidize sacrificially and produce direct electrical current to protect a more electropositive (noble) metal operating in the same electrolyte and produced to a desired shape by the solidification of a molten alloy in a mold or die.

Cathodic protection

The prevention or reduction of corrosion of metal by making the metal the cathode in a galvanic or electrolytic cell.

Closed circuit potential

The potential of an anode connected to a structure when passing current; normally measured against a reference electrode in a particular environment.

Cold lap

Horizontal discontinuity caused by solidification of the meniscus of partially cast anode as a result of interrupted flow of the casting stream. The solidified meniscus is covered with metal when the flow resumes. Cold laps can occur along the length of an anode.

Cold shut

Horizontal surface discontinuity caused by solidification of a portion of a meniscus during the progressive filling of a mold, which is later covered with more solidifying metal as the molten metal level rises. Cold shuts generally occur at corners remote from the point of pour.

Cracking

Fracture of metal along an irregular path producing a discontinuity similar to a ragged edge. It can occur during the solidification of the anode (hot cracking), during the contraction of the anode after solidification, or under externally applied loads. Hot cracking may be associated with the shrinkage depression that can occur in open-topped molds.

Current capacity

The total current flow available from an anode of given mass of alloy; normally expressed as ampere years per kilogram. This is the inverse of the anode consumption rate.

Current density

The average amount of current entering or leaving a given surface area.

Driving potential

The difference between the open circuit potentials of the anode and the structure.

Dulling of steel

Deterioration in appearance of shot-blasted inserts because of oxidation that causes darkening of the surface but not rust discoloration (see Rust Discoloration).

Electrochemical properties

Those properties of potential and current capacity that characterize a sacrificial anode and can be assessed by quantitative tests.

Gas holes

The evidence of bubbles within the solidifying metal. The holes can indicate that moisture was on the mold or insert prior to casting, or that the liquid metal contained a high level of hydrogen that had been thrown out of solution to form bubbles during the cooling of the metal.

Gross anode mass

Total mass of an anode, including anode core.

Heat

Also called a "melt" or "cast", it is the unit that defines molten metal and identifies the anodes cast from it. A heat is the product that is cast to a planned procedure in one melting operation in one furnace, without significant interruption. If the casting sequence is interrupted, the anodes produced before, between, and after the interruptions constitute "batches".

Inserts

The form over which the anode is cast and which is used to connect the anode to the structure requiring protection. These are sometimes referred to as "cores".

Net anode mass

Mass of actual anode alloy.

Nonmetallic inclusions

Particles of oxides and other refractory materials entrapped in liquid metal during the melting or casting sequences.

Open circuit potential

The potential of an anode when not connected to a structure; normally measured against a reference electrode in a particular environment.

Porosity

Generally distributed fine holes caused by gas bubbles, shrinkage (formed by the starvation of eutectic material within the dendrite arms during "unfed" solidification), or a combination of the two mechanisms when hydrogen in solution diffuses into the lower pressure shrinkage voids.

Protrusion

Extraneous material on the anode surface. It may interfere with the anode-to-structure fit, appear unattractive, and be a safety hazard if there are sharp edges. Protrusions can be formed by careless filling of the mold or the flash from imperfect fitting of mold sections.

Reference electrode

An electrode which has a stable potential in one or more electrolytes, thus enabling it to be used for the measurement of other electrode potentials at a given temperature.

Rimming (rimmed) steels

An incompletely deoxidized steel. (See ASM Metals Handbook, 7th. Edition for exhaustive definition.)

Rust discoloration

A brown bloom of iron oxide.

Sample

A representative specimen.

Shrinkage depression

The natural concave surface produced when liquid metal is allowed to solidify in a container without the provision of extra liquid metal to compensate for the reduction in volume that occurs during the liquid-solid transformation. The term also applies to the concave surface produced when liquid metal is solidified in a closed mold in such a manner that the area is not "fed" by the liquid metal provided by the casting's riser.

Tap sample

A specimen taken from a molten metal stream. Such samples may be taken at the commencement of pouring and then at regular intervals until a final sample is taken at the end of the pour.

Voids adjacent to insert

Visible spaces between anode and insert materials. These can be caused by surface evaporation of moisture from the insert, contraction of the insert, or movement of the insert during casting caused by uneven heating and expansion that distorts the insert and prevents it from returning to its original, desired position within the anode.

4. UNITS

This Standard is based on International System of Units (SI), except where otherwise specified.

5. TECHNICAL DOCUMENTS

The manufacturer and/or supplier shall provide the following procedures with reference to this Standard specification:

5.1 Production procedures that cover all stages of the manufacturing process, from receipt of raw materials to finishing and packing for shipment, including:

- chemical analysis;
- surface preparation;
- measurements of weights, dimensions, bowing, twisting, crack size, etc.;
- inspection and testing procedures, including acceptance criteria, and frequencies;
- anode manufacture;
- identification of rejected anodes.

5.2 Insert bending, welding and preparation procedures: including acceptance limits for wall thinning and ovality, nondestructive testing procedures, surface profile measurements.

5.3 Electrochemical test procedures, including acceptance criteria, description of test apparatus, measurement methods and preparation and cleaning of samples.

5.4 Preservation, packing and shipping procedures, such that anodes are not damaged or deformed and do not deteriorate during handling, delivery to the fabrication yard, storage: including methods, materials and any requirement for periodic inspections.

5.5 The manufacturer and/or supplier shall provide manufacturing drawings as detailed bellow for

approval. Details to be shown on anode detail drawings for each pipe size shall be as follows:

- Dimensions and tolerances.
- Details of frame design.
- Details of fixing lugs.
- Alloy type.
- Net weight.
- Gross weight.
- Location of markings.
- Details of electrical connections.

5.6 Anode manufacture shall not commence until all relevant documents, manufacturing drawings and the Quality and Inspection plan and supporting procedures have been approved.

5.7 The manufacturer and/or supplier shall submit to the Purchaser his quality assurance and control plan.

6. MATERIALS AND MANUFACTURE

6.1 General

6.1.1 The electrochemical properties are highly dependent on the content of alloying elements and impurity elements. The anode manufacturer shall thus prove his capability of delivering anodes which satisfy this Part of Standard specification.

6.1.2 Small deviations from the specification in the alloy composition may significantly reduce the protective properties. Generally it is of importance that the fabrication procedure ensures that the melt is not polluted by iron or other impurities. Furnaces, pumps, pipes, etc., shall be non-metallic or properly lined.

6.1.3 Manufacturing of anodes shall be carried out using approved production procedures covering each stage of the process from supply of raw materials to finishing and packing for shipment. The procedures shall be fully referenced in an Inspection and Test plan which shall also refer to requirements of this Part of Standard specification, as applicable.

6.1.4 The manufacturer shall ensure that full traceability of all the materials is maintained throughout the manufacturing process.

The manufacturer shall submit the Purchaser his quality assurance and control plan.

6.1.5 The quality control at the anode manufacturing plant shall include control systems on the following:

- Raw materials, i.e., checking of documentation.
- Production equipment and process.
- Testing during and after production (see 6.3).
- Identification of anodes.
- Chemical analysis (see 6.3.1).
- Weight and dimensional tolerances.
- Surface condition of produced anodes.
- Documentation (material certificates).

6.2 Alloy Composition

6.2.1 Aluminum anodes

The aluminum anodes shall conform to the chemical composition specified in Table 1 as determined by spectrographic and other methods specified herein.

6.2.2 Zinc anodes

The zinc anodes shall be made from special High Grade Zinc conforming to ASTM specification B 6, with suitable alloying additions. The anodes shall conform to the chemical composition given in Table 2 in order to reduce the susceptibility to intergranular corrosion at elevated temperature.

The zinc anode composition in this specification meets the chemical composition requirements of ASTM specification B418 (Type I) and US Military specification MIL-A-18001 H.

TABLE 1 - CHEMICAL COMPOSITION LIMITS FOR ALUMINUM ANODES

ELEMENT	CHEMICAL COMPOSITION, PERCENT	
	min.	max.
Silicon	---	0.10
Iron	---	0.10
Copper	---	0.006
Zinc	3.0	5.0
Indium	0.02	0.05
Other Elements:		
- Each	---	0.02
- Total	---	0.05
Aluminum	Remainder	

TABLE 2 - CHEMICAL COMPOSITION LIMITS FOR ZINC ANODES

ELEMENT	CHEMICAL COMPOSITION, PERCENT	
	min.	max.
Cadmium	0.03	0.06
Aluminum	0.1	0.2
Iron	---	0.002
Lead	---	0.006
Copper	---	0.005
Other Elements:		
- Each	---	---
- Total	---	0.1
Zinc	Remainder	

Certificates of analysis shall be submitted for all elements above 0.01%, in addition to the elements above listed, and shall state that all other elements are below this limit.

6.3 Production Testing

The manufacturer shall carry out the following production tests:

6.3.1 Chemical analysis

6.3.1.1 No anode casting shall commence before confirming by chemical analysis that the alloy constituents fall within the range specified in 6.2.

6.3.1.2 A full spectrographic analysis, or an approved alternative, shall be made of representative samples taken at the beginning and end of each melt to prove that the chemical composition is within the limits of the alloy specification stated in 6.2. If one of these analysis is out of the specified range, the heat will be rejected.

6.3.1.3 The equipment used for chemical analysis shall be calibrated at the start of each shift using reference samples. Calibration samples shall be independently certified.

6.3.1.4 If alloying additions are made in holding furnaces or crucibles, then analysis shall be made at the beginning and end of pouring from the holding furnace or crucible.

6.3.1.5 No additions of whatever kind shall be made to the melt following a spectrographic analysis showing the material to be within specification and before commencement of pouring.

6.3.1.6 Each heat shall be assigned a unique number which shall be transferred to all samples taken from that heat and to all records pertaining to that heat. All samples shall be indestructibly marked with the unique heat number.

6.3.1.7 At least two further samples, taken at the same frequency as those for spectrographic analysis, in the form of sticks of approximately 30 mm diameter × 200 mm length shall be retained from each heat for use in electrochemical testing.

6.3.1.8 All samples shall be retained for a minimum of 2 years beyond completion of the supply contract and may be subjected to independent analysis and testing.

6.3.2 Short term voltage testing

A short term voltage test shall be carried out on one representative sample from each heat.

The voltage test shall be carried out in natural seawater or synthetic sea water (to the composition specified in ASTM D 1141) at 20°C.

For aluminum anodes refer to Subclause 8.5.

For zinc anodes the test shall be performed at an anodic current density of 0.75 mA/cm² and duration of test shall be 3 hours min. The anode working potentials shall be respectively minus 1000 mV and minus 1050 mV. VS SCE reference electrode.

6.3.3 Short term capacity testing for aluminum anodes only

A short duration capacity test shall be carried out on one representative sample of each heat.

One-fifth of the number of heats to be tested, with minimum one test per order.

The test procedure shall be in accordance with Appendix B. Anode material capacity shall be determined by weight loss (see 8.4). The Anode capacity shall not be less than 2500 Ah/kg.

6.3.4 Anodes failing the above electrochemical tests acceptance criteria shall be rejected. However, a minimum of two new samples for re-tests may be cut from two different anodes of the same heat number as the original failed test pieces. In case even one of these two give negative results, the entire heat will be rejected, or all the anodes shall be tested individually. In case both of them give acceptable results, the remaining part of the heat is accepted.

6.3.5 Destructive and non-destructive testing

6.3.5.1 One anode shall be selected for sectioning at random from each of 150 produced anodes, in addition to the first sectioned anode taken at the start of production.

6.3.5.2 The selected anode shall be transverse sectioned by single cuts at 25%, 33% and 50% of the nominal length and once longitudinally.

6.3.5.3 The cut faces, when examined visually without magnification, shall be free from visible slag/dross inclusions.

6.3.5.4 Total porosity in any sectioned surface shall not exceed 0.25% of the alloy area, with no individual pores or void greater than 10 mm².

6.3.5.5 The lack of bonding between the anode and the core shall not exceed 5% of the core peripheral length in any sectioned surface.

6.3.5.6 Should any anode section fail to meet the above criteria, the subsequent anode cast shall be also sectioned. If this also fails, the entire production batch (since the last successful section) shall be quarantined and a series of backchecks made in order to allow acceptance of part batches.

6.3.5.7 Alternatively to destructive testing a non-destructive testing by radiography may be used to check for lack of bond or slag/dross inclusions.

7. ANODE CORE STEEL WORKS

7.1 Insert Material

7.1.1 The anode material shall be cast around a steel insert so designed as to retain the anode material even when it is consumed to its design utilization factor. The steel inserts shall have sufficient strength to withstand all external forces that they may normally encounter.

7.1.2 The anode insert shall meet the requirements of EN 10025 Grade Fe 430C. The maximum carbon content of the steel to be welded shall not exceed 0.23%.

7.1.3 The carbon equivalent of the insert materials shall not exceed 0.45%, determined using the following formula:

$$\text{Carbon equivalent} = C + \frac{Mn}{6} + \frac{Cr + Mo + V}{5} + \frac{Ni + Cu}{15}$$

Where each element is expressed in weight percent.

7.1.4 Rimming steels shall not be used.

7.1.5 All materials shall be identified against original mill certificates.

7.2 Insert Surface Preparation

7.2.1 Inserts shall be stored indoors at a humidity not exceeding 85% with steel temperature maintained at least 3°C above the dew point.

7.2.2 For aluminum anodes, the steel fabrication to be inserted into the cast anode shall be prepared by a dry blast cleaning process to a minimum quality complying with ISO 8501-1, Grade SA 2½ or equivalent standard.

7.2.3 At the time the aluminum anodes are cast, "dulling" of the blast cleaned surface of the insert shall be permitted. Rust discoloration and/or visible surface contamination shall not be permitted.

7.2.4 For zinc anodes, the steel fabrication to be inserted into the cast anode shall be prepared by dry blast cleaning process to a minimum quality complying with ISO 8501-1 Grade SA 2½ or equivalent standard, galvanizing to BS 729, or Zinc electroplating to BS 1706, or equivalent standards.

7.2.5 At the time the zinc anode is cast, "dulling" of blast cleaned or zinc coated steel insert surfaces shall be permitted. Rust discoloration and/or visible surface contamination of the blast

cleaned or zinc coated surface shall not be permitted.

7.2.6 Inserts not used within 8 hours of blast cleaning, or showing signs of rusting, moisture, grease, oil or other surface contamination, shall be re-cleaned.

7.3 Welding

7.3.1 All fabrication welding and acceptance tests on anode insert shall be in accordance with AWS D1.1, latest edition.

7.3.2 Welding procedures and welder qualifications shall be in accordance with AWS D1.1, latest edition.

7.3.3 All welds shall be visually inspected and be free of deleterious defects. Adequate examination of production welds shall be carried out by appropriate non-destructive testing.

8. REQUIREMENTS

8.1 Anode Shape, Weight and Dimensions

8.1.1 Shape

The shape of anodes, as will be specified by the Purchaser, may be either plain half-shell or tapered half-shell.

Notes:

1) The plain half-shell bracelet is used when the pipe is concrete coated and shall be manufactured so that the internal diameter fits over the outside diameter of the wrap/composition coat and matches the outside diameter of the concrete.

2) The tapered half-shell bracelet is for pipes without concrete, the purpose of the taper being to enable the anodes more easily to traverse the stringer rolls of the lay-barge.

8.1.2 Weight

8.1.2.1 The individual casting (half-shell pairs) net weight shall be within $\pm 3\%$ of the net weight shown on the drawings.

8.1.2.2 All half-shell anodes and their cores shall be weighed individually to confirm compliance. The individual weights shall be recorded. The total supplied net weight shall be no more than 2% above and not below the nominal supplied weight.

8.1.3 Dimensions

8.1.3.1 The anode dimensions shall conform to the tolerances indicated by the manufacturer and/or supplier in the approved drawings.

8.1.3.2 The position of the insert in the casting shall be within 5 mm of the design position, as an average over the length, and not more than 10 mm from the design position at any point.

8.1.3.3 Anodes shall be free from excessive bowing or twisting. The manufacturer shall fabricate a suitable template for the half-shell bracelet anodes. Complete bracelets shall be assembled around

the template to ensure compliance with the diametrical tolerances specified on the drawings.

8.1.3.4 Anode insert cross section dimensions shall comply with the appropriate specification for the insert material used. Full dimensional checks shall be carried out to ensure compliance with the approved drawing for the insert material used.

8.2 Mechanical Resistance

When an uniaxial force equivalent to 100 kg, or five times the mass of the anode metal, whichever is the greater, is applied to a cast anode containing a core, no movement of the core or any metal insert shall occur.

8.3 Electrical Resistance

When determined in accordance with the test method in Appendix A, the electrical resistance of the anode to core shall be not greater than 0.01 Ω for the life of the anode.

8.4 Consumption Rate of Aluminum Anodes in Seawater

When determined in accordance with the test method in Appendix B, the consumption rate of an aluminum anode in seawater shall not exceed 3.5 kg/A. year.

Note:

The test specified in Appendix B is applicable to aluminum anodes only. Typical consumption rates for zinc anodes in seawater is given in Table 3.

8.5 Closed Circuit Potential of Aluminum Anodes in Seawater

When determined in accordance with Appendix C, the closed-circuit potential of an aluminum anode shall be at least - 1.05 V with respect to a silver/silver chloride reference electrode.

Note:

The test specified in Appendix C is relevant for aluminum anodes only.

TABLE 3 - TYPICAL PROPERTIES OF ZINC ANODES

OPEN CIRCUIT POTENTIAL, Ea. REFERENCE ELECTRODE		TYPICAL ANODE CONSUMPTION RATE IN SEAWATER kg/A. YEAR
Cu/CuSO ₄	Ag/AgCl	
-1.1	-1.05	12

8.6 Surface Irregularities in the Anode Casting

8.6.1 Shrinkage depressions in the casting shall not exceed 10% of the nominal thickness of the anode as measured from the uppermost corner of the depression to its bottom.

8.6.2 The anode casting shall be free from non-metallic inclusions. Cold shuts or surface laps shall not exceed a depth of 10 mm or extend over a total length of more than 150 mm.

8.6.3 All protrusion detrimental to the safety of personnel during handling shall be removed. No further grinding or mechanical treatment of the anode surface shall be permitted.

8.6.4 All anodes shall be inspected visually to confirm compliance with the above.

8.7 Cracks in Cast Anodes Material

8.7.1 Within the section of sacrificial anodic material wholly supported by the core, transverse cracks shall not be permitted except in the form of micro (hairline) cooling cracks with a maximum width of 2 mm and a length not greater than 75% of the anode bracelet diameter or 200 mm whichever is smaller. A maximum of two cracks per casting (halfshell) shall be allowed. Small close cracks shall be taken as one crack.

8.7.2 No cracks shall be allowed in anodic material unsupported by the core.

8.7.3 Cracks which extend around two or more faces of the anode shall not be permitted.

8.7.4 Longitudinal cracks shall not be permitted.

8.7.5 All castings shall be visually inspected to ensure compliance with the above.

8.8 Anode Connections

8.8.1 Two anode connections, for bonding to the pipe, shall be attached to each bracelet half-shell. Electrical connection to the pipeline shall be by means of four 16 mm² cables per anode to be thermit welded to the pipeline after anode installation.

8.8.2 The lead wires shall be 16 sq.mm single core, stranded soft annealed copper conductor conforming to IEC 228 Class 2, minimum length 250 mm.

8.8.3 The lead wire insulation, as will be specified by the Purchaser, shall be in accordance with one of the following alternatives:

- A single jacket of High Molecular Weight Polyethylene (HMWPE) conforming to ASTM D 1351, having a minimum thickness of 1.5 mm.
- A single jacket of Cross-Linked Polyethylene (XLPE) conforming to ASTM specification D 2655, having a minimum thickness of 1 mm.
- A double jacket of Polyvinyl Chloride (PVC) primary insulation as per ASTM D 2219, sheathed with a Polyvinyl Chloride (PVC) extruded jacket conforming to ASTM D 1047. The average thickness (of insulation and sheath) shall be 2 mm with a 10% tolerance.

8.8.4 Lead wire insulation shall have a minimum 600 volt rating.

8.8.5 Unless otherwise specified, the color of lead wire insulation shall be red.

8.8.6 The insulation shall be applied tightly to the conductor without adhering to it and shall form a compact and homogeneous body. The lead wire insulation shall be completely free of cracks, nicks, scratches, or other discontinuities.

9. INSPECTION

9.1 Responsibility for Inspection and Tests

9.1.1 The manufacturer and/or supplier shall be responsible for carrying out all the tests and inspections (during and after fabrication) required by this Part of Standard specification, using his own or other reliable facilities, and he shall maintain complete records of all such tests and inspections. Such records shall be available for review by the Purchaser.

9.1.2 The manufacturer and/or supplier shall afford the Purchaser's inspector all reasonable facilities necessary to satisfy him that the material is being produced and furnished in accordance with this Part of Standard specification.

9.1.3 The Purchaser reserves the right to perform any inspections set forth in the specification where such inspections are deemed necessary to assure that supplies and services conform to the

prescribed requirements. Such inspections in no way relieve the manufacturer and/or supplier of his responsibilities under the term of this Part of Standard specification.

9.1.4 The Purchaser's inspector shall have access to the material subject to inspection for the purpose of witnessing the selection of the samples, the preparation of the test pieces, and the performance of the test(s). For such tests, the inspector shall have the right to indicate the pieces from which the samples will be taken in accordance with the provisions of this Part of Standard specification.

9.1.5 The manufacturer shall inspect the material covered by this Standard specification prior to shipment and shall furnish to the Purchaser a certificate of inspection stating that each lot has been sampled, tested, and inspected in accordance with this Part of Standard specification and has been found to meet the requirements specified.

9.2 Inspection

9.2.1 Inspection shall cover the following as a minimum:

9.2.1 Dimensional checking, identification, weight, and quality of castings on at least 5% of the number of anodes from each cast.

9.2.2 Quality of steel inserts before casting, and surface preparation on at least 5% of inserts for the batch of anodes from each cast.

9.2.3 Quality of steel-anode bonding on the anode from each order, selected for destructive testing.

9.2.4 Inspection of results of spectro analysis, voltage tests, capacity tests and destructive testing done by manufacture (see 6.3).

9.2.5 After transport to installation site, a final visual check to be carried out to ensure that anodes have not been damaged during transport and handling.

10. ACCEPTANCE/REJECTION

10.1 Acceptance/rejection of anodes will be on a total inspection of all anodes (see 9).

10.2 Where any of the requirements, mentioned in this Part of Standard specification, are not met, the anodes and the relevant batch of anodes will be rejected.

11. SUPPLIED DOCUMENTATION

The following documentation shall be supplied with each anode batch:

- The anode batch and cast numbers.
- Details of anode casting weights (net and gross) and numbers.
- Steel core mill certification.
- Results of any destructive testing.
- Results of any non-destructive testing.
- Electrochemical test results.
- Anode alloy chemical analysis results.
- Material specification and trade name.
- The anode manufacturer.
- The Company's order No.
- The date of manufacture.
- Certificate of conformity with this Part of Standard specification.

12. ORDERING INFORMATION

(See Appendix D.)

13. PACKING AND SHIPMENT

Anodes shall be bundled, strapped, placed on pallets, or in sturdy crates with supports, pads and binding as necessary to facilitate unloading and minimize damage to anodes during normal handling and transportation.

Cleaning, preservation, and packaging of anodes shall be in accordance with the manufacturer's commercial practice, provided they are such as to ensure acceptance by common or other carriers for safe transportation to the delivery point.

14. LABELING

14.1 Identification of Anodes

The following information shall be legibly and durably marked on each anode supplied, or on a label securely fixed to each anode:

- a) The name or registered mark of the manufacturer.
- b) The alloy designation (trade name).
- c) Nominal net mass of the anode.
- d) Batch number.
- e) Cast number.

Notes:

- 1) The same identification shall appear on all samples taken for testing.
- 2) The numbers of any rejected anodes shall not be used again for replacement anodes.

14.2 Marking of Container

Each pallet shall be plainly marked with the following information:

- Name:
- Specification: [IPS-M-TP-750](#): Part 5
- Order No.:
- M.E.S.C No.:
- Anode Type:
- Anode Weight (Net and Gross):
- Anode Dimensions:
- Batch No.:
- Stock No.:
- Date of Manufacture:
- Quantity:
- Manufacturer's Name and Address:

Note:

Each pallet shall be clearly marked "FRAGILE".

APPENDICES**APPENDIX A**
METHOD FOR THE DETERMINATION OF THE ANODE-TO-CORE
RESISTANCE OF GALVANIC ANODES**A.1 General**

This Appendix describes the method for the determination of the anode-to-core resistance of galvanic (sacrificial) anodes used for cathodic protection.

A.2 Principle

The voltage across the anode metal and anode core is measured when a known current is passed between them. The anode-to-core resistance is then computed by dividing the measured voltage by the known current.

A.3 Apparatus

The following apparatus is required:

- a) A d.c. supply of 5 A capacity, with an adjustable current control capable of smooth variation from 5 A to near zero. It shall be capable of generating an on-load-voltage sufficient to pass a current of 5 A through a resistance of not less than 1Ω .
- b) An ammeter capable of reading to at least 5 A d.c. with a maximum error of $\pm 1\%$ at full scale deflection. This ammeter may be integral with the d.c. supply (see Item (a)).
- c) A millivoltmeter of the electrically protected type capable of reading to 50 mV d.c., with a maximum error of $\pm 1\%$.
- d) Suitable test leads and clamps or clips to connect Items (a), (b) and (c) to the anode and the core. The clamp system shall be of such quality to ensure that the connection resistance to each point is less than 0.05Ω .

A.4 Circuit

The circuit shall be arranged as shown in Fig. A.1 (a) or (b), as applicable. The leads connecting the millivoltmeter to the anode and the anode core (or cable), shall be independent of the leads from the power supply. All connections shall be properly made to minimize contact resistance.

If the millivoltmeter is connected across the anode metal and the terminal of the cable attached to the anode core, the anode-to-core resistance is obtained by subtracting the cable resistance from the total resistance. The total resistance is computed by dividing the measured potential by the known current.

A.5 Procedure

The procedure shall be as follows:

- a) Before connecting the power supply, set the variable current control to ensure a minimum current flow when the circuit is switched on.
- b) Connect the power supply. Adjust the variable current control until approximately 5 A is registered on the ammeter.

(to be continued)

APPENDIX A (continued)

- c) Read the voltage difference as indicated by the millivoltmeter.
- d) Calculate the anode-to-core resistance (R), in ohms, using the following equation:

$$R = \frac{\text{millivoltmeter reading (in volts)}}{\text{ammeter reading (in amperes)}}$$

- e) Reverse both ammeter supply leads and also the millivoltmeter supply leads, and repeat Steps (a) to (d) above. The result of this second calculation of R should be the same as the initial result.

A.6 Report

The test report shall contain the following information:

- a) Name of test laboratory.
- b) Identification of the equipment used to carry out the test.
- c) Identification of the galvanic anode tested.
- d) The date on which the test was carried out.
- e) The results of the anode-to-core resistance test calculations.
- f) Reference to this test method.

(to be continued)

APPENDIX A (continued)

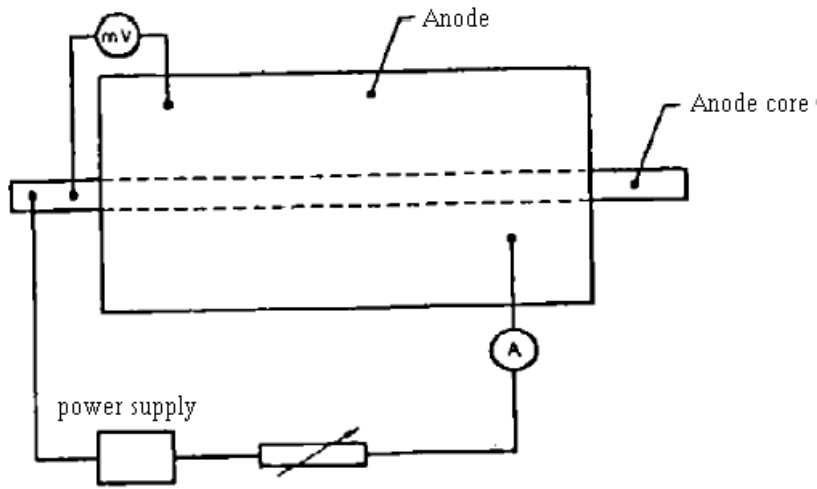

a) Without cable attached

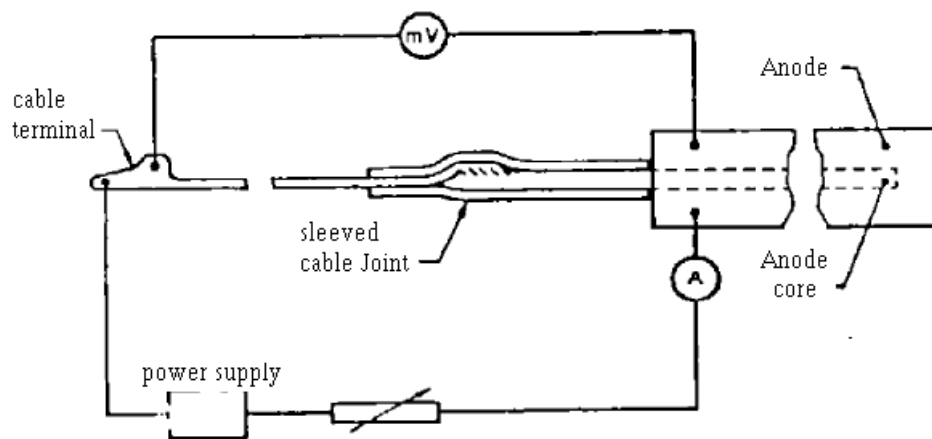

b) With cable attached

SCHEMATIC CIRCUITS FOR MEASUREMENT OF ANODE-TO-CORE RESISTANCE

Fig. A.1

APPENDIX B
METHOD FOR THE DETERMINATION OF THE CONSUMPTION RATE
OF ALUMINUM ANODE ALLOYS IMMERSSED IN SEAWATER

B.1 General

This Appendix describes the method for the determination of the consumption rate of aluminum anode alloys intended for use in cathodic protection of ferrous metals immersed in seawater.

Note:

The anode alloy consumption rate, expressed in kilograms per ampere year, is an important factor when the performance of different alloys for the sacrificial protection of ferrous metal structures in seawater is being assessed. The consumption rate may be used to compute the current capacity of an anode system.

B.2 Principle

The loss of anode mass, which occurs when a known quantity of current flows from the anode to the cathode in seawater, is computed to show the quantity of anode metal consumed in one year by the passage of 1 A.

B.3 Apparatus

The following apparatus is required:

- a) A constant current d.c. power supply with an output voltage appropriate to the number of test cells in series, and having sufficient current capacity to maintain the specified anode current density. The output current stability of the power supply shall be within $\pm 1\%$.
- b) An ammeter to suit the current requirement, and having a maximum error of $\pm 1\%$. This ammeter may be integral with the power supply (see Item (a)).
- c) Aluminum cathodes; one per aluminum anode.
- d) Non-metallic tanks; one per anode, to hold seawater.
- e) Clean seawater with a resistivity of not greater than $0.3 \Omega \cdot \text{m}$ at 20°C , or synthetic seawater conforming to the requirements of ASTM D 1141.
- f) An agitator.

B.4 Circuit

The circuit shall be arranged as shown in Fig. B.1.

B.5 Preparation of Test Anodes

The as-manufactured anode surface is preferred for test purposes, however cut and machined surfaces are not excluded for use in this test. All anodes used in the same test series shall have the same nominal composition and the same area dimensions exposed to seawater.

Any mounting strap or wiring conductor shall be covered to prevent contact with seawater.

(to be continued)

APPENDIX B (continued)

The anodes shall be cleaned in nitric acid (e_{20} 1420 kg/m³) at ambient temperature and then thoroughly rinsed in clean fresh water and dried.

B.6 Procedure

The anode consumption rate shall be determined as follows:

- a) Weight each anode and record its mass.
- b) Connect the circuit as shown in Fig. B.1.
- c) Adjust the power supply to produce a current output equivalent to a current density of between 0.5 mA/cm² and 0.7 mA/cm² of anode surface area. Note the time of commencement of the test and the set current value.
- d) Change the seawater when 0.1 A.h has passed for each 1 L of seawater in a cell.
- e) Continue the test for a period of at least 10 days.

Note:

The longer the test period the more reliable will be the result.

f) Remove the test anodes from the cells. Clean, rinse and dry the test anodes in accordance with Paragraph B.5, and reweight.

g) Calculate the alloy consumption rate for each anode, in kilograms per ampere year, using the following equation:

$$\text{Alloy consumption rate} = \frac{\text{mass loss} \times 8760}{\text{total current flow}}$$

Where:

mass loss is in kilograms;

total current flow is in ampere hours.

Express the result to the nearest 0.1 kg/A. year.

(to be continued)

APPENDIX B (continued)

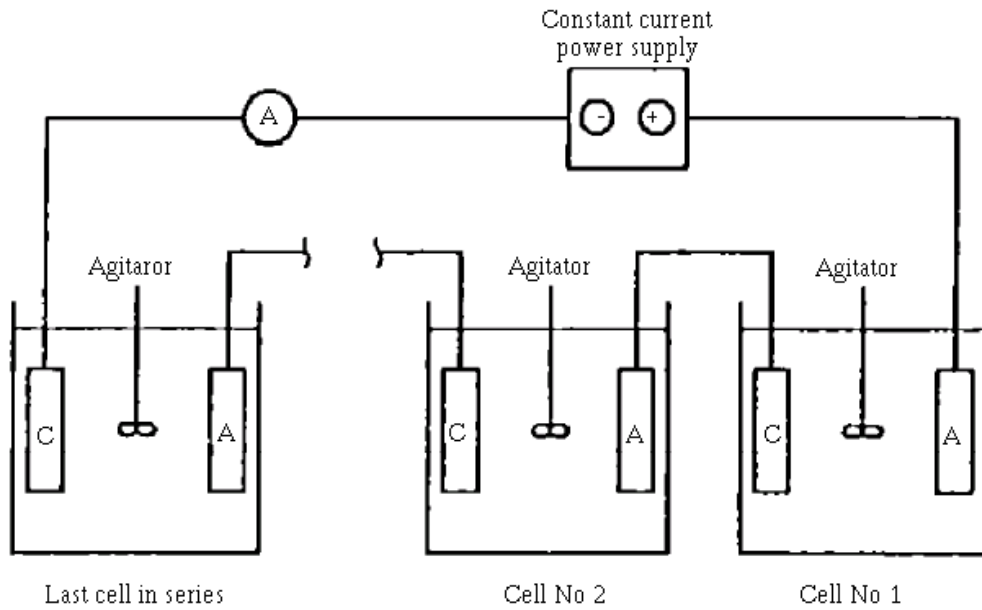

Legend:

C = cathode

A = anode

SCHEMATIC CIRCUIT FOR DETERMINATION OF ALLOY CONSUMPTION RATE

Fig. B.1

B.7 Report

The report shall contain the following information:

- a) Name of the test laboratory.
- b) Identification of the equipment used to carry out the test.
- c) Identification of the anode material.
- d) The mass of each anode before and after completion of the test.
- e) Other test details including the test period.
- f) The dates during which the test was carried out.
- g) The test results.
- h) Reference to this test method.

APPENDIX C
METHOD FOR THE DETERMINATION OF THE CLOSED-CIRCUIT
POTENTIAL OF ALUMINUM ANODES IMMERSSED IN SEAWATER

C.1 General

This Appendix describes the method for the determination of the closed-circuit potential of aluminum anodes intended for use in the cathodic protection of ferrous metals immersed in seawater.

Note:

The closed-circuit potential, as distinct from the open-circuit potential, is a critical factor when assessing the ability of galvanic anodes to protect ferrous metal structures in service.

C.2 Principle

The closed-circuit potential is measured when current is flowing between an anode and cathode in seawater, by locating a reference cell close to the anode surface.

C.3 Apparatus

The following apparatus is required:

- a) A 12 V d.c. power source with a variable resistance to maintain the specified anode current density.
- b) A suitable ammeter.
- c) A high resistance voltmeter with a minimum input resistance of $1\text{ M}\Omega/V$ and a resolution of 10 mV or better, and having a maximum error of $\pm 1\%$ at full scale deflection.
- d) A silver/silver chloride or saturated calomel reference electrode.
- e) An aluminum cathode.
- f) A non-metallic tank to hold seawater.
- g) Fixed resistors of equal value. The voltage drop across each fixed resistor shall be at least 10 V.
- h) Clean seawater with a resistivity of not greater than $0.3\Omega \cdot \text{m}$ at 20°C , or synthetic seawater conforming to the requirements of ASTM D 1141.

C.4 Circuit

The circuit shall be arranged as shown in Fig. C.1 to enable the testing of one of a series of anodes. All anodes in the circuit shall have the same nominal composition and shape and the same area dimensions exposed to the seawater.

Any mounting, wiring conductor or anode connection shall be insulated at the air/water interface to prevent contact with seawater.

C.5 Preparation of Test Anode

For test purposes, it is preferred that the surface of the anode is in the as-manufactured condition, however cut and machined surfaces are also acceptable.

(to be continued)

APPENDIX C (continued)

C.6 Procedure

The closed-circuit potential shall be determined using the following procedure:

- a) Arrange the equipment so that the anode-to-cathode distances are approximately the same, and the current flow is not affected by cell geometry or adjacent anodes.
- b) Adjust the test anode current density to a value between 0.5 mA/cm^2 and 0.7 mA/cm^2 and record the time of commencement of current flow. Change the seawater when 0.1 A.h has passed for each litre of seawater contained in the tank.
- c) Record, to the nearest 0.01 V, the closed-circuit potential on the voltmeter. Continue the test until three consecutive stable readings are obtained at time intervals of 1 h.
- d) Report the last three stable closed-circuit potential readings obtained with respect to the reference cell, for the anode under test.
- e) Repeat Steps (a) to (d) for each anode tested to enable duplication of the results.

C.7 Report

The report shall contain the following information:

- a) Name of the test laboratory.
- b) Identification of the equipment used to carry out the test, the reference cell, details of the circuit and details of the seawater used.
- c) Identification of the anode material, and number and dimensions of anodes in the circuit.
- d) The current density used, test procedure details and resultant closed circuit potential readings (in duplicate).
- e) The date of testing.
- f) Reference to this test method.

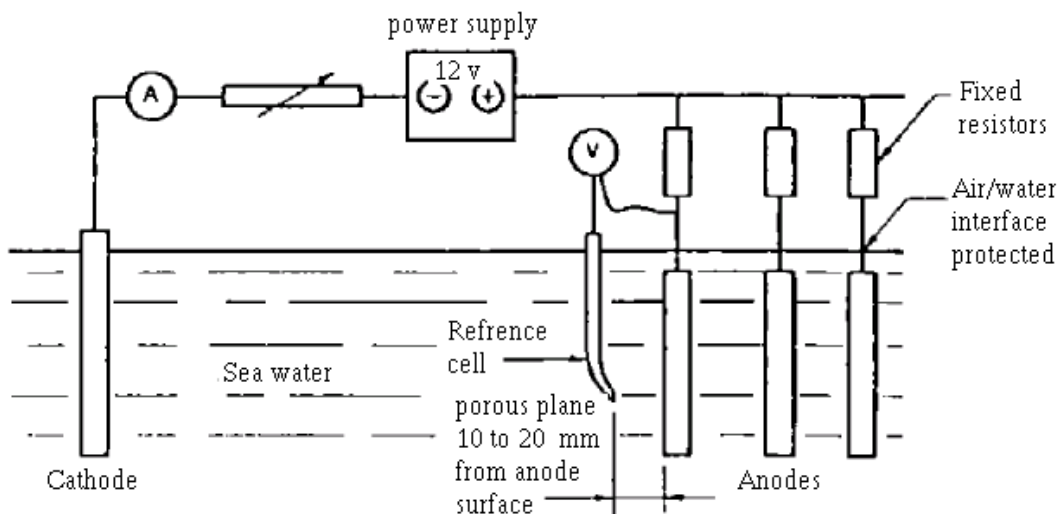

SCHEMATIC CIRCUIT FOR MEASUREMENT OF CLOSED-CIRCUIT POTENTIAL

Fig. C.1

**APPENDIX D
DATA SHEET****(TO BE SUBMITTED BY THE PURCHASER)****FOR****IPS-M-TP-750: Part 5 BRACELET GALVANIC ANODES**

The anodes shall be in accordance with the latest edition of above Iranian Petroleum Standard with the following specific requirements:

- Project title: - Date:
- Indent No.: - Purchaser:.....
- M.E.S.C. No.: - No. of Anodes:
- Project title: - Date:
- Type of Anode: b Aluminum Anode b Zinc Anode
- Anode Shape: b Plain Half-Shell
 b Tapered Half-Shell
- Anode lead wire insulation: b Single Jacket HMWPE
 b Single Jacket XLPE
 b Double Jacket PVC/PVC
- Pipe O.D.:
- Pipe coating: Type:
 Thickness:
- Antiflotation coating: Type:
 Thickness:
- Environmental conditions:

PART 6

CAST GALVANIC ANODES

FOR

FIXED OFFSHORE INSTALLATIONS

(ALUMINUM)

CONTENTS :	PAGE No.
1. SCOPE	84
2. REFERENCES	84
3. DEFINITIONS AND TERMINOLOGY	84
4. UNITS	87
5. TECHNICAL DOCUMENTS	87
6. MATERIALS AND MANUFACTURE	88
7. REQUIREMENTS	91
8. INSPECTION AND TESTING	93
9. ACCEPTANCE/REJECTION	94
10. SUPPLIED DOCUMENTATION	94
11. INFORMATION TO BE SUPPLIED BY THE PURCHASER	94
12. PACKING AND SHIPMENT	95
13. MARKING	95
 APPENDICES:	
APPENDIX A METHOD FOR THE DETERMINATION OF THE ANODE-TO-CORE RESISTANCE OF GALVANIC ANODES	96
APPENDIX B METHOD FOR THE DETERMINATION OF THE CONSUMPTION RATE OF ALUMINUM ANODE ALLOYS IMMERSSED IN SEAWATER	98
APPENDIX C METHOD FOR THE DETERMINATION OF THE CLOSED-CIRCUIT POTENTIAL OF ALUMINUM ANODES IMMERSSED IN SEAWATER	101
APPENDIX D TYPICAL MASSES AND DIMENSIONS OF PLATFORM ALUMINUM ANODES	103
APPENDIX E ALUMINUM ANODES TYPICAL FIXING ARRANGEMENTS	104

1. SCOPE

This Part of [IPS-M-TP-750](#) covers the minimum requirements for the material, manufacture, inspection and testing of cast sacrificial anodes made of Aluminum-zinc-indium, intended for use on fixed offshore installations.

This Standard specification covers only the general requirements for the aluminum anodes, the specific requirements will be given in pertinent ordering documents.

2. REFERENCES

Throughout this Standard the following dated and undated standards/codes are referred to. These referenced documents shall, to the extent specified herein, form a part of this standard. For dated references, the edition cited applies. The applicability of changes in dated references that occur after the cited date shall be mutually agreed upon by the Company and the Vendor. For undated references, the latest edition of the referenced documents (including any supplements and amendments) applies.

API (AMERICAN PETROLEUM INSTITUTE)

API 5L "Specification for Linepipe"

ASTM(AMERICAN SOCIETY FOR TESTING AND MATERIALS)

B660M Standard Practice for "Packaging/Packing of Aluminum and Magnesium Products"

D1141 "Substitute Ocean Water"

E101 Standard Test Method for

"Spectrographic Analysis of Aluminum and Aluminum Alloys by the Point-to-Plane Technique"

E716 Standard Practice for

"Sampling Aluminum and Aluminum Alloys for Spectrochemical Analysis"

BSI (BRITISH STANDARDS INSTITUTION)

BS EN

10 204 "Metallic Products-Types of Inspection Documents"

ISO (INTERNATIONAL ORGANIZATION FOR STANDARDIZATION)

8501-1 "Preparation of Steel Structures Before Application of Paints and Related Products-Visual Assessment of Surface Cleanlines"

3. DEFINITIONS AND TERMINOLOGY

For the purpose of this Standard, the definitions below apply:

Anode consumption rate

The rate of alloy mass consumption for a given current output over a given period; normally stated in kilograms per ampere year.

Cast sacrificial anode

The negative (reactive) component of a galvanic cell, designed to oxidize sacrificially and produce direct electrical current to protect a more electropositive (noble) metal operating in the same electrolyte and produced to a desired shape by the solidification of a molten alloy in a mold or die.

Certificate of conformity

A statement made by the producer's representative (executive) and endorsed by a representative of the customer that the anodes listed comply with the requirements of the order.

Cold lap

Horizontal discontinuity caused by solidification of the meniscus of a partially cast anode as a result of interrupted flow of the casting stream. The solidified meniscus is covered with metal when the flow resumes. Cold laps can occur along the length of an anode.

Closed circuit potential

The potential of an anode connected to a structure when passing current; normally measured against a reference electrode in a particular environment.

Cold shut

Horizontal surface discontinuity caused by solidification of a portion of a meniscus during the progressive filling of a mold, which is later covered with more solidifying metal as the molten metal level rises. Cold shuts generally occur at corners remote from the point of pour.

Cracking

Fracture of metal along an irregular path producing a discontinuity similar to a ragged edge. It can occur during the solidification of the anode (hot cracking), during the contraction of the anode after solidification, or under externally applied loads. Hot cracking may be associated with the shrinkage depression that can occur in open-topped molds.

Current capacity

The total current flow available from an anode of given mass of alloy; normally expressed as ampere years per kilogram. This is the inverse of the anode consumption rate.

Current density

The average amount of current entering or leaving a given surface area.

Dulling of steel

Deterioration in appearance of shot-blasted inserts because of oxidation that causes darkening of the surface but not rust discoloration (see Rust Discoloration).

Electrochemical properties

Those properties of potential and current capacity that characterize a sacrificial anode and can be assessed by quantitative tests.

Gas holes

The evidence of bubbles within the solidifying metal. The holes can indicate that moisture was on the mold or insert prior to casting, or that the liquid metal contained a high level of hydrogen that had been thrown out of solution to form bubbles during the cooling of the metal.

Gross anode mass

Total mass of an anode, including anode core.

Heat

Also called a "melt" or "cast", it is the unit that defines molten metal and identifies the anodes cast from it. A heat is the product that is cast to a planned procedure in one melting operation in one furnace, without significant interruption. If the casting sequence is interrupted, the anodes produced before, between, and after the interruptions constitute "batches".

Inserts

The form over which the anode is cast and which is used to connect the anode to the structure requiring protection. These are sometimes referred to as "cores".

Low carbon steels

Steels having less than 0.30% carbon and no intentional alloying additions.

Net anode mass

Mass of actual anode alloy.

Nonmetallic inclusions

Particles of oxides and other refractory materials entrapped in liquid metal during the melting or casting sequences.

Open circuit potential

The potential of an anode when not connected to a structure; normally measured against a reference electrode in a particular environment.

Porosity

Generally distributed fine holes caused by gas bubbles, shrinkage (formed by the starvation of eutectic material within the dendrite arms during "unfed" solidification), or a combination of the two mechanisms when hydrogen in solution diffuses into the lower pressure shrinkage voids.

Protrusion

Extraneous material on the anode surface. It may interfere with the anode-to-structure fit, appear unattractive, and be a safety hazard if there are sharp edges. Protrusions can be formed by careless filling of the mold or the flash from imperfect fitting of mold sections.

Reference electrode

An electrode which has a stable potential in one or more electrolytes, thus enabling it to be used for the measurement of other electrode potentials at a given temperature.

Rimming (rimmed) steels

An incompletely deoxidized steel. (See ASM Metals Handbook, 7th. Edition for exhaustive definition.)

Rust discoloration

A brown bloom of iron oxide.

Sample

A representative specimen.

Shrinkage depression

The natural concave surface produced when liquid metal is allowed to solidify in a container without the provision of extra liquid metal to compensate for the reduction in volume that occurs during the liquid-solid transformation. The term also applies to the concave surface produced when liquid metal is solidified in a closed mold in such a manner that the area is not "fed" by the liquid metal provided by the casting's riser.

Tap sample

A specimen taken from a molten metal stream. Such samples may be taken at the commencement of pouring and then at regular intervals until a final sample is taken at the end of the pour.

Voids adjacent to insert

Visible spaces between anode and insert materials. These can be caused by surface evaporation of moisture from the insert, contraction of the insert, or movement of the insert during casting caused by uneven heating and expansion that distorts the insert and prevents it from returning to its original, desired position within the anode.

4. UNITS

This Standard is based on International System of Units (SI), except where otherwise specified.

5. TECHNICAL DOCUMENTS

The Vendor shall provide full documentation on the following:

- a) Manufacturing drawings for anodes: including dimensions, tolerances, steel, grade, alloy type and weights.
- b) Production procedures that cover all stages of the manufacturing process, from receipt of raw materials to finishing and packing for shipment, including:
 - chemical analysis;
 - surface preparation;
 - measurements of weights, dimensions, bowing, twisting, crack size, etc.;
 - inspection and testing procedures, including acceptance criteria, and frequencies;
 - anode manufacture;
 - identification of rejected anodes.
- c) Insert bending, welding and preparation procedures: including acceptance limits for wall

thinning and ovality, non-destructive testing procedures, surface profile measurements.

d) Electrochemical test procedures, including acceptance criteria, description of test apparatus, measurement methods and preparation and cleaning of samples.

e) Preservation, packing and shipping procedures, such that anodes are not damaged or deformed and do not deteriorate during handling, delivery to the fabrication yard, storage: including methods, materials and any requirement for periodic inspections.

Any certificates issued by an inspection agency shall be included in the documentation.

6. MATERIALS AND MANUFACTURE

6.1 General

6.1.1 The electrochemical properties are highly dependent on the content of alloying elements and impurity elements. The anode manufacturer shall thus prove his capability of delivering anodes which satisfy this Part of Standard specification.

6.1.2 Small deviations from the specification in the alloy composition may significantly reduce the protective properties. Generally it is of importance that the fabrication procedure ensures that the melt is not polluted by iron or other impurities. Furnaces, pumps, pipes, etc., shall be non-metallic or properly lined.

6.1.3 The quality control at the anode manufacturing plant shall include control systems on the following:

- Raw materials, i.e., checking of documentation.
- Production equipment and process.
- Testing during and after production.
- Identification of anodes.
- Chemical analysis.
- Weight and dimensional tolerances.
- Surface condition of produced anodes.
- Documentation (material certificates).

6.2 Type of Anodes

6.2.1 The anodes shall be of the "stand-off" type, cast in Aluminum-Zinc-Indium sacrificial alloy, with a minimum stand-off distance of 150 mm, and can have a trapezoid or cylindrical shape.

6.2.2 The alloy shall be proven to be free from passivity and intergranular corrosion for the conditions specified in ordering/purchasing documents.

6.2.3 The anodes shall be sufficiently rigid to avoid vibration in the anode support.

6.3 Chemical Composition

The anodes shall conform to the chemical composition specified in Table 1 as determined by spectrographic and other methods specified herein.

TABLE 1 - CHEMICAL COMPOSITION LIMITS ^{a)}

ELEMENT		COMPOSITION, % BY WEIGHT
Silicon,	max	0.10
Iron,	max	0.10
Copper,	max	0.006
Zinc		3.0 - 5.0
Indium		0.02 - 0.05
Other elements, each,	max	0.02
Other elements, total ^{b)} ,	max	0.05
Aluminum		Remainder ^{c)}

a) Analysis shall regularly be made only for the elements specified in this table. If, however, the presence of other elements is suspected or indicated in amounts greater than the specified limits, further analysis shall be made to determine that these elements are not present in amounts in excess of the specified limits.

b) Other Elements - Total shall be the sum of unspecified metallic elements 0.010% or more, rounded to the second decimal before determining the sum.

c) The aluminum content shall be calculated by subtracting from 100.00%.

6.4 Production Testing

The manufacturer shall carry out the following production testing:

6.4.1 Chemical analysis

6.4.1.1 Two samples from each melt shall be taken for chemical analysis. The samples shall be taken in the beginning and at the end of casting from the pouring string.

For smaller alloying furnaces (approx. 500 kg) it is sufficient to take one sample per batch. The sample shall be taken at the beginning of one batch, at the end of the next and so on.

Sampling shall be in accordance with ASTM Practice E716 or approved alternative standard.

6.4.1.2 Analysis shall be by spectrographic analysis in accordance with ASTM Test Method E 101 or approved alternative standard, in case of dispute, the methods of analysis shall be agreed upon by the Purchaser and supplier.

6.4.1.3 If one of these analysis is out of the specified range, the heat will be rejected. Individual anodes may be accepted subject to further analysis, at the option of the Purchaser.

6.4.2 Electrochemical testing for quality control

6.4.2.1 Checking of closed-circuit-potential and current capacity shall be done for each 10 ton produced anodes, with minimum one test per order. The test samples may be separately casted or cut directly from an anode.

6.4.2.2 The testing shall preferably be carried out by a body independent of the manufacturer.

6.4.2.3 The methods of testing should be in accordance with Appendices B and C.

6.4.3 Destructive and non-destructive testing

6.4.3.1 At least one anode per delivery or at least 0.5% of the anodes, where net weight of the anode exceeds 100 kg, shall be subject to destructive testing to check the bonding between anode material and steel core in cross-sectional areas.

6.4.3.2 All sectioning shall be carried out in the presence of purchaser's inspector(s).

6.4.3.3 Anodes shall be sectioned transversely, by single cuts, at 25%, 33% and 50% of nominal cast length.

6.4.3.4 Anodes shall be sectioned once longitudinally through the center line/pour point.

6.4.3.5 Not more than 5% of the insert peripheral length in any sectioned surface shall show visible lack of bond between the insert and the cast alloy.

6.4.3.6 There shall be no visible pores and slag/dross inclusions in any sectioned surface.

6.4.3.7 Total porosity in any sectioned surface shall not exceed 0.25% of the alloy area, with no individual pores or voids greater than 10 mm².

6.4.3.8 Should any anode section fail to meet the above criteria, the subsequent anode cast shall also be sectioned. If this also fails, the entire production batch (since the last successful section) shall be quarantined and a series of backchecks made in order to allow acceptance of part batches. Acceptance of quarantined anodes shall be at the sole discretion of Purchaser's inspector(s). The problem shall be investigated, and the cause corrected to Purchaser's inspector satisfaction, before production continues.

6.4.3.9 Alternatively to destructive testing a non-destructive testing by radiography may be used to check for lack of bond or slag/dross inclusions.

6.5 Anode Insert

6.5.1 Insert material

6.5.1.1 The platform anode insert shall be cut from unspliced weldable seamless low alloy carbon steel line pipe to API 5L, Grade B or approved equivalent standard.

6.5.1.2 The steel inserts shall have sufficient strength to withstand all external forces that they may normally encounter.

6.5.1.3 The carbon equivalent (C_{ev}) of the insert materials shall not exceed 0.45 percent, determined using the following formula:

$$C_{ev} = C + \frac{Mn}{6} + \frac{Cr + Mo + V}{5} + \frac{Ni + Cu}{15}$$

Where each element is expressed in weight percent.

6.5.1.4 Rimming steels shall not be used.

6.5.1.5 Mill certificates shall conform to the requirements of BS EN 10 204, Part 3.1.B, and shall be obtained for all steel used in the manufacture of inserts.

6.5.1.6 For low temperature applications, consideration shall be given to the notch toughness of material; in particular, to the toughness of the material to be welded to the parent structure.

6.5.2 Insert surface preparation

6.5.2.1 All anode inserts shall be blast cleaned to ISO 8501-1, Grade SA 2½ prior to anode casting.

Sand shall not be used for blast cleaning. The surface profile of the cleaned surface shall be 50 to 100 microns.

6.5.2.2 Inserts shall be stored indoors at a humidity not exceeding 85% and such that the steel temperature is maintained at least 3°C above the dew point.

6.5.2.3 Inserts not used within 8 hours of blast cleaning, or any which show signs of rusting or surface contamination, or which do not conform to ISO 8501-1 Grade SA 2½ at time of casting, shall be re-cleaned in accordance with the requirements of 6.5.2.1.

6.5.2.4 At the time the anodes are cast, "dulling" of the blast cleaned surface of the insert shall be permitted. Rust discoloration and/or visible surface contamination shall not be permitted.

6.5.3 Insert fabrication

6.5.3.1 All fabrication welding and acceptance tests on anode insert shall be in accordance with AWS D1.1 latest edition, or approved equivalent standard.

Welding procedures and welder qualifications shall be in accordance with AWS D1.1, latest edition, or approved equivalent standard.

6.5.3.2 All welds shall be visually inspected and be free of deleterious defects. Adequate examination of production welds shall be carried out by appropriate non-destructive testing.

6.5.3.3 Tubular inserts shall be bent using purpose-built equipment. The manufacturer shall confirm that the bend radii given on the contract drawings are suitable. Surface cracking and wrinkling on the inside surface of the bend shall not be acceptable.

6.5.3.4 The manufacturer shall ensure that the necessary controls are placed on the heat treatment condition, and other relevant parameters, of the tube material so as to permit satisfactory bending of inserts.

6.5.3.5 Where inserts are pre-heated prior to pouring of aluminum alloy, the manufacturer shall provide appropriate control and measurement of the insert temperature and shall ensure that the specified standard of cleanliness is maintained.

6.5.3.6 Inserts shall be held rigidly during casting.

6.5.4 Insert position

The position of the insert in the platform anode casting shall be within 5 mm of the design position as an average over the anode length and not more than 10 mm from the design position at any point.

7. REQUIREMENTS

7.1 Casting Quality

7.1.1 Each anode shall be cast in one pour. Intermediate solidification's are not acceptable. Cold shuts or surface laps shall not be permitted.

7.1.2 Anodes shall be topped up prior to final solidification to present a top cast surface free from shrinkage cavities and depressions. Overpouring after solidification shall not be permitted.

7.1.3 No grinding or other surface treatment shall be permitted except that which shall be carried out to remove mould flashing or other protrusions that might present a safety hazard.

7.1.4 All protrusions detrimental to the safety of personnel during handling shall be removed.

7.1.5 The anode surface shall be free from cracks which may reduce the performance of the anode.

7.1.6 Any cracks which follow the longitudinal direction of anodes are not acceptable.

7.1.7 Smaller cracks in the transverse direction may be acceptable provided the cracks would not cause any mechanical failure during service of the anode. The combination of cracks and lack of bond to the anode core is detrimental.

For transverse cracks, the following limits should be used:

- Cracks with a length of less than 50 mm and width less than 5 mm are normally acceptable.
- Cracks with a length of 50 - 200 mm should be limited to 2 per anode face or 4 per anode.
- Cracks with a length of more than 200 mm or which are more than 5 mm in width are not acceptable.

7.1.8 The anode surface shall be free from any significant slag/dross inclusions or anything that may be considered detrimental to the satisfactory performance of the anodes. There shall be no visible disbondment from the insert surface.

7.1.9 Shrinkage depressions shall not exceed 100 mm in length, 12 mm in width and 10 mm depth.

7.1.10 Casting surface irregularities shall be fully bonded to the bulk anodic material.

7.1.11 Not more than 1% of the total surface of the anode casting shall be contaminated with non metallic inclusions visible to the naked eye.

7.1.12 Reduction in cross section of anodic material adjacent to the emergence of inserts shall not exceed 10% of the nominal anode cross section.

7.1.13 Anode inserts protruding from the anodes shall be smooth and free of sharp edges.

7.2 Weight and Dimensional Tolerances

7.2.1 The weight tolerance on individual anodes shall be within $\pm 3\%$ of the specified net weight.

7.2.2 The total contract weight shall be no more than 2% above and not below the nominal contract weight.

7.2.3 Dimensional tolerances shall conform to the following:

- Diameter of cylindrical anodes: ± 7.5
- Width : $\pm 5\%$
- Depth : $\pm 10\%$
- Length (for anodes > 1 m long): ± 25 mm
- (for shorter anodes): $\pm 2.5\%$

7.2.4 The straightness of the anode shall not deviate more than 2% of the anode nominal length from the longitudinal axis of the anode.

7.2.5 The anode insert location within stand-off anodes shall at least be within $\pm 5\%$ of the nominal position in anode width and length and within 10% of the nominal position in anode depth.

7.2.6 Anode insert cross section dimensions shall comply with the appropriate specification for the insert material used.

7.3 Performance Requirements

7.3.1 Mechanical resistance

When an uniaxial force equivalent to 100 kg, or five times the mass of the anode metal, whichever is the greater, is applied to a cast anode containing a core, no movement of the core or any metal

insert shall occur.

7.3.2 Electrical resistance

When determined in accordance with the test method in Appendix A, the electrical resistance of the anode to core shall not be greater than 0.01 Ω for the life of the anode.

7.3.3 Consumption rate in seawater

When determined in accordance with the test method in Appendix B, the consumption rate of an aluminum anode in seawater shall not exceed 3.5 kg/A year.

7.3.4 Closed circuit potential in seawater

When determined in accordance with Appendix C, the closed-circuit potential of an aluminum anode shall be at least -1.05 V with respect to a silver/silver chloride reference electrode.

7.4 Identification of Anodes

Each anode shall be clearly marked with the type of material (trade name), the cast number, and a piece of serial number. The numbers of any rejected anodes shall not be used again for replacement anodes.

7.5 Anode Protection

Before storage outside, the open ends of the platform anode inserts shall be sealed against water ingress by the use of non-metallic end caps.

The supplier shall notify purchaser of any extra requirements to be carried out in order to prevent deterioration of the anodes and inserts.

8. INSPECTION AND TESTING

8.1 Responsibility for Inspection and Tests

8.1.1 Unless otherwise specified, the manufacturer and/or supplier shall be responsible for carrying out all the tests and inspections required by this Part of Standard specification using his own or other reliable facilities, and he shall maintain complete records of all such tests and inspections. Such records shall be available for review by the Purchaser.

8.1.2 The manufacturer and/or supplier shall afford the Purchaser's inspector all reasonable facilities necessary to satisfy him that the material is being produced and furnished in accordance with this Part of Standard specification.

8.1.3 The Purchaser reserves the right to perform any inspections set forth in the specification where such inspections are deemed necessary to assure that supplies and services conform to the prescribed requirements.

8.1.4 The Purchaser's inspector shall have access to the material subject to inspection for the purpose of witnessing the selection of the samples, the preparation of the test pieces, and the performance of the test(s). For such tests, the inspector shall have the right to indicate the pieces from which the samples will be taken in accordance with the provisions of this Part of Standard specification.

8.1.5 The manufacturer shall inspect the material covered by this Part of Standard specification prior to shipment and shall furnish to the Purchaser a certificate of inspection stating that each lot

has been sampled, tested, and inspected in accordance with this Part of Standard specification and has been found to meet the requirements specified.

8.1.6 If the Purchaser desires that his representative inspect or witness the inspection and testing of the product prior to shipment, the producer or supplier shall afford the Purchaser's representative all reasonable facilities to satisfy him that the product meets the requirements of this Part of Standard specification. Such inspections in no way relieve the supplier/ manufacturer of his responsibilities under the term of this Part of Standard specification.

8.2 Inspection

Inspection shall cover the following as a minimum:

8.2.1 Dimensional checking, identification, weight, and quality of castings on at least 5% of the number of anodes from each cast.

8.2.2 Quality of steel inserts before casting, and surface preparation on at least 5% of inserts for the batch of anodes from each cast.

8.2.3 Quality of steel-anode bonding on the anode from each order, selected for destructive testing.

8.2.4 Inspection of results of spectro analysis, voltage tests, capacity tests, and destructive testing done by manufacturer.

9. ACCEPTANCE/REJECTION

9.1 Acceptance/rejection of anodes will be on a total inspection of all anodes.

9.2 Where any of the requirements, mentioned in this Part of Standard specification, are not met, the anodes and the relevant batch of anodes will be rejected.

10. SUPPLIED DOCUMENTATION

The following documentation shall be supplied with each anode batch:

- The anode batch and cast numbers.
- Details of anode casting weights (net and gross) and numbers.
- Steel core mill certification.
- Results of any destructive testing.
- Results of any non-destructive testing.
- Electrochemical test results.
- Anode alloy chemical analysis results.
- Material specification and trade name.
- The anode manufacturer.
- The Company's Order No.
- The date of manufacture
- Certificate of conformity with this Part of Standard specification.

11. INFORMATION TO BE SUPPLIED BY THE PURCHASER

The Purchaser shall supply the following information at the time of enquiry:

- a) Title, number, and date of this Part of Standard specification.

b) Nominal anode shape and dimensions, and whether a standard or non-standard anode is required.

Note:

The ordering/purchasing documents shall specify required dimensions of anode, steel core, and brackets and net and gross weight of anodes, or alternatively reference shall be made to a supplier's standard type and size of anode or anode assembly.

c) Design life.

d) Seawater temperature range.

e) Seawater depth.

f) Whether it is the intention of the Purchaser to inspect the anodes at the supplier's work.

g) Any additional packaging and labeling requirements.

12. PACKING AND SHIPMENT

12.1 Anodes shall be packaged to provide adequate protection during shipment, handling and transportation. Cleaning, preservation, and packaging of anodes shall be in accordance with the manufacturer's commercial practice, provided that they are such as to ensure acceptance by common or other carriers for safe transportation at the lowest rate to the delivery point.

12.2 When specified in the contract or purchase order, anodes shall be preserved, packaged, and packed in accordance with the requirements of ASTM Practice B 660M. The applicable levels shall be as specified in the contract or order.

13. MARKING

Each pallet shall be plainly marked with the following information:

- Name:
- Specification: [IPS-M-TP-750](#): Part 6
- Order No.:
- M.E.S.C No.:
- Anode type:
- Anode weight (net and gross):
- Anode dimensions:
- Batch No.:
- Stock No.:
- Date of manufacture:
- Quantity (number of anodes):
- Manufacturer's name and address.

Note:

Each pallet shall be clearly marked "FRAGILE".

APPENDICES**APPENDIX A****METHOD FOR THE DETERMINATION OF THE ANODE-TO-CORE
RESISTANCE OF GALVANIC ANODES****A.1 General**

This Appendix describes the method for the determination of the anode-to-core resistance of galvanic (sacrificial) anodes used for cathodic protection.

A.2 Principle

The voltage across the anode metal and anode core is measured when a known current is passed between them. The anode-to-core resistance is then computed by dividing the measured voltage by the known current.

A.3 Apparatus

The following apparatus is required:

- a) A d.c. supply of 5A capacity, with an adjustable current control capable of smooth variation from 5A to near zero. It shall be capable of generating an on-load-voltage sufficient to pass a current of 5A through a resistance of not less than 1 Ω .
- b) An ammeter capable of reading to at least 5A d.c. with a maximum error of $\pm 1\%$ at full scale deflection. This ammeter may be integral with the d.c. supply (see Item (a)).
- c) A millivoltmeter of the electrically protected type capable of reading to 50 mV d.c., with a maximum error of $\pm 1\%$.
- d) Suitable test leads and clamps or clips to connect Items (a), (b) and (c) to the anode and the core. The clamp system shall be of such quality to ensure that the connection resistance to each point is less than 0.05 Ω .

A.4 Circuit

The circuit shall be arranged as shown in Fig. A.1. The leads connecting the millivoltmeter to the anode and the anode core, shall be independent of the leads from the power supply. All connections shall be properly made to minimize contact resistance.

If the millivoltmeter is connected across the anode metal and the terminal of the cable attached to the anode core, the anode-to-core resistance is obtained by subtracting the cable resistance from the total resistance. The total resistance is computed by dividing the measured potential by the known current.

A.5 Procedure

The procedure shall be as follows:

- a) Before connecting the power supply, set the variable current control to ensure a minimum current flow when the circuit is switched on.
- b) Connect the power supply. Adjust the variable current control until approximately 5A is registered on the ammeter.

(to be continued)

APPENDIX A (continued)

- c) Read the voltage difference as indicated by the millivoltmeter.
- d) Calculate the anode-to core resistance (R), in ohms, using the following equation:

$$R = \frac{\text{millivoltmeter reading (in volts)}}{\text{ammeter reading (in amperes)}}$$

- e) Reverse both ammeter supply leads and also the millivoltmeter supply leads, and repeat Steps (a) to (d) above. The result of this second calculation of R should be the same as the initial result.

A.6 Report

The test report shall contain the following information:

- a) Name of test laboratory.
- b) Identification of the equipment used to carry out the test.
- c) Identification of the galvanic anode tested.
- d) The date on which the test was carried out.
- e) The results of the anode-to-core resistance test calculations.
- f) Reference to this test method.

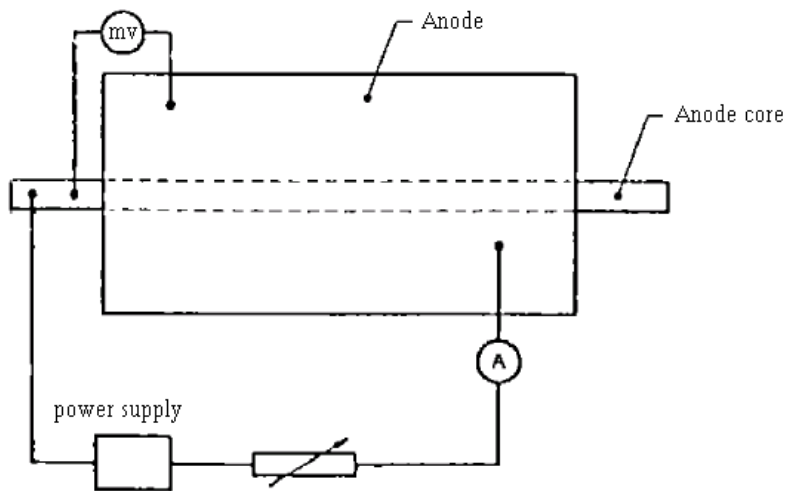

SCHEMATIC CIRCUITS FOR MEASUREMENT OF ANODE-TO-CORE RESISTANCE

Fig. A.1

APPENDIX B
METHOD FOR THE DETERMINATION OF THE CONSUMPTION
RATE OF ALUMINUM ANODE ALLOYS IMMERSSED IN SEAWATER

B.1 General

This Appendix describes the method for the determination of the consumption rate of aluminum anode alloys intended for use in cathodic protection of ferrous metals immersed in seawater.

Note:

The anode alloy consumption rate, expressed in kilograms per ampere year, is an important factor when the performance of different alloys for the sacrificial protection of ferrous metal structures in seawater is being assessed. The consumption rate may be used to compute the current capacity of an anode system.

B.2 Principle

The loss of anode mass, which occurs when a known quantity of current flows from the anode to the cathode in seawater, is computed to show the quantity of anode metal consumed in one year by the passage of 1 A.

B.3 Apparatus

The following apparatus is required:

- a) A constant current d.c. power supply with an output voltage appropriate to the number of test cells in series, and having sufficient current capacity to maintain the specified anode current density. The output current stability of the power supply shall be within $\pm 1\%$.
- b) An ammeter to suit the current requirement, and having a maximum error of $\pm 1\%$. This ammeter may be integral with the power supply (see Item (a)).
- c) Aluminum cathodes; one per aluminum anode.
- d) Non-metallic tanks; one per anode, to hold seawater.
- e) Clean seawater with a resistivity of not greater than $0.3 \Omega \cdot \text{m}$ at 20°C , or synthetic seawater conforming to the requirements of ASTM D 1141.
- f) An agitator.

B.4 Circuit

The circuit shall be arranged as shown in Fig. B.1.

B.5 Preparation of Test Anodes

The as-manufactured anode surface is preferred for test purposes, however cut and machined surfaces are not excluded for use in this test. All anodes used in the same test series shall have the same nominal composition and the same area dimensions exposed to seawater.

Any mounting strap or wiring conductor shall be covered to prevent contact with seawater.

(to be continued)

APPENDIX B (continued)

The anodes shall be cleaned in nitric acid (e_{20} 1420 kg/m³) at ambient temperature and then thoroughly rinsed in clean fresh water and dried.

B.6 Procedure

The anode consumption rate shall be determined as follows:

- a) Weigh each anode and record its mass.
- b) Connect the circuit as shown in Fig. B.1.
- c) Adjust the power supply to produce a current output equivalent to a current density of between 0.5 mA/cm² and 0.7 mA/cm² of anode surface area. Note the time of commencement of the test and the set current value.
- d) Change the seawater when 0.1 A.h has passed for each 1 L of seawater in a cell.
- e) Continue the test for a period of at least 10 days.

Note:

The longer the test period the more reliable will be the result.

f) Remove the test anodes from the cells. Clean, rinse and dry the test anodes in accordance with Paragraph B.5, and reweight.

g) Calculate the alloy consumption rate for each anode, in kilograms per ampere year, using the following equation:

$$\text{Alloy consumption rate} = \frac{\text{mass loss} \times 8760}{\text{total current flow}}$$

Where:

mass loss is in kilograms;

total current flow is in ampere hours.

Express the result to the nearest 0.1 kg/A.Year.

(to be continued)

APPENDIX B (continued)

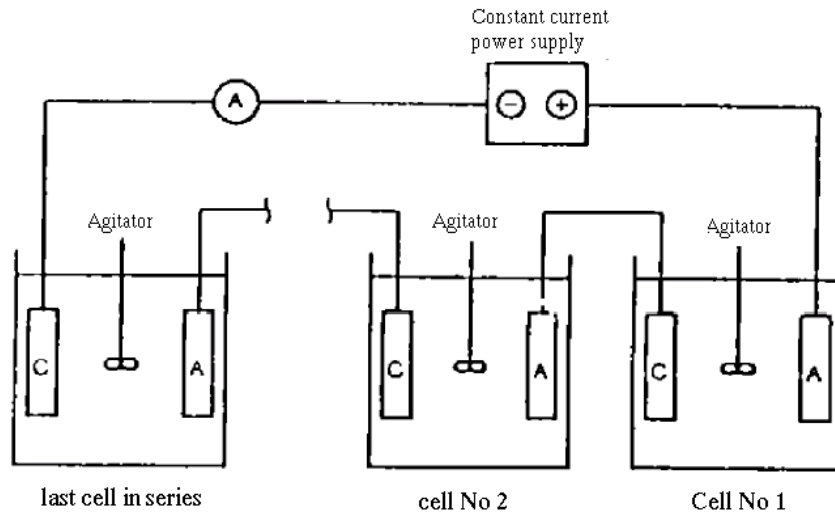

Legend:

- C = cathode
- A = anode

SCHEMATIC CIRCUIT FOR DETERMINATION OF ALLOY CONSUMPTION RATE**Fig. B.1****B.7 Report**

The report shall contain the following information:

- a) Name of the test laboratory.
- b) Identification of the equipment used to carry out the test.
- c) Identification of the anode material.
- d) The mass of each anode before and after completion of the test.
- e) Other test details including the test period.
- f) The dates during which the test was carried out.
- g) The test results.
- h) Reference to this test method.

APPENDIX C
METHOD FOR THE DETERMINATION OF THE CLOSED-CIRCUIT
POTENTIAL OF ALUMINUM ANODES IMMERSSED IN SEAWATER

C.1 General

This Appendix describes the method for the determination of the closed-circuit potential of aluminum anodes intended for use in the cathodic protection of ferrous metals immersed in seawater.

Note:

The closed-circuit potential, as distinct from the open-circuit potential, is a critical factor when assessing the ability of galvanic anodes to protect ferrous metal structures in service.

C.2 Principle

The closed-circuit potential is measured when current is flowing between an anode and cathode in seawater, by locating a reference cell close to the anode surface.

C.3 Apparatus

The following apparatus is required:

- a) A 12 V d.c. power source with a variable resistance to maintain the specified anode current density.
- b) A suitable ammeter.
- c) A high resistance voltmeter with a minimum input resistance of 1 Ω m/V and a resolution of 10 mV or better, and having a maximum error of $\pm 1\%$ at full scale deflection.
- d) A silver/silver chloride or saturated calomel reference electrode.
- e) An aluminum cathode.
- f) A non-metallic tank to hold seawater.
- g) Fixed resistors of equal value. The voltage drop across each fixed resistor shall be at least 10 V.
- h) Clean seawater with a resistivity of not greater than 0.3 Ω .m at 20°C, or synthetic seawater conforming to the requirements of ASTM D 1141.

C.4 Circuit

The circuit shall be arranged as shown in Fig. C.1 to enable the testing of one of a series of anodes. All anodes in the circuit shall have the same nominal composition and shape and the same area dimensions exposed to the seawater.

Any mounting strap, wiring conductor or anode connection shall be insulated at the air/water interface to prevent contact with seawater.

C.5 Preparation of Test Anode

For test purposes, it is preferred that the surface of the anode is in the as-manufactured condition, however cut and machined surfaces are also acceptable.

(to be continued)

APPENDIX C (continued)

C.6 Procedure

The closed-circuit potential shall be determined using the following procedure:

- a) Arrange the equipment so that the anode-to-cathode distances are approximately the same, and the current flow is not affected by cell geometry or adjacent anodes.
- b) Adjust the test anode current density to a value between 0.5 mA/cm^2 and 0.7 mA/cm^2 and record the time of commencement of current flow. Change the seawater when 0.1 A.h has passed for each litre of seawater contained in the tank.
- c) Record, to the nearest 0.01 V, the closed-circuit potential on the voltmeter. Continue the test until three consecutive stable readings are obtained at time intervals of 1 h.
- d) Report the last three stable closed-circuit potential readings obtained with respect to the reference cell, for the anode under test.
- e) Repeat Steps (a) to (d) for each anode tested to enable duplication of the results.

C.7 Report

The report shall contain the following information:

- a) Name of the test laboratory.
- b) Identification of the equipment used to carry out the test, the reference cell, details of the circuit and details of the seawater used.
- c) Identification of the anode material, and number and dimensions of anodes in the circuit.
- d) The current density used, test procedure details and resultant closed-circuit potential readings (in duplicate).
- e) The date of testing.
- f) Reference to this test method.

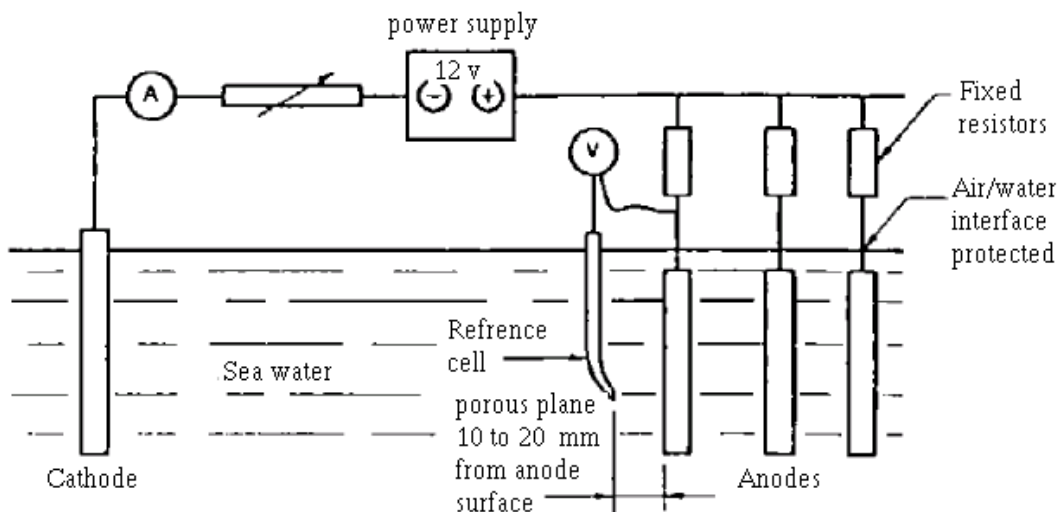

SCHEMATIC CIRCUIT FOR MEASUREMENT OF CLOSED-CIRCUIT POTENTIAL

Fig. C.1

APPENDIX D

TYPICAL MASSES AND DIMENSIONS OF PLATFORM ALUMINUM ANODES

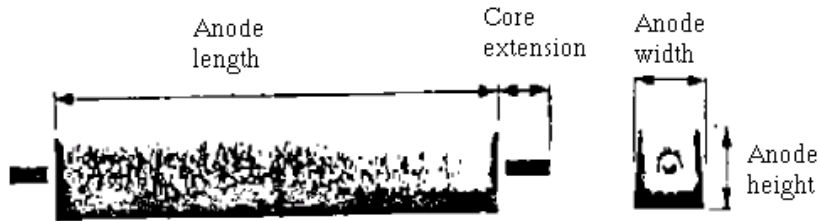

ANODE TYPE	ANODE LENGTH Mm	ANODE WIDTH Mm	ANODE HEIGHT mm	CORE EXTENSION mm	CORE DIAMETER mm	NET WEIGHT kg	GROSS WEIGHT kg
350	1320	102	102	152	19	35	38
680	1525	133	127	152	19	68	72
1190	1550	184	159	152	25	119	126
1480	2440	160	162	152	60	148	170
2400	2750	207	207	152	114	240	306
3300	2440	252	244	152	114	330	391
4350	3000	254	257	152	114	435	507
5650	3048	283	283	152	114	565	640

All weights and dimensions are nominal.

APPENDIX E
ALUMINUM ANODES TYPICAL FIXING ARRANGEMENTS



1. Double "J" plate extension for close mounting



2. single "J" plate extension for close mounting

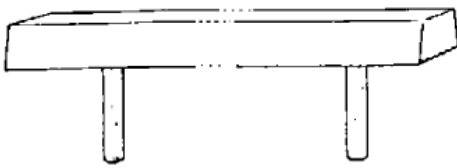

3. Tubular stand-off arms from anode body



4. Standard core stand-off arms with T-section "bookends"

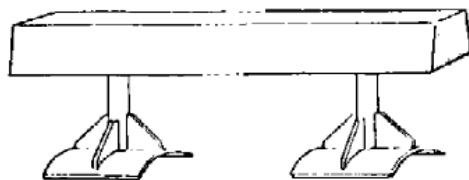

5. Tubular stand-off arms from anode body with gussets and double plate.

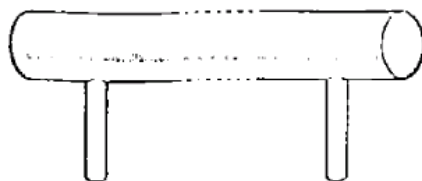

6. cylindrical anode variant of 3 above.

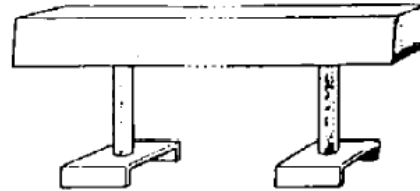

7. Tubular stand-off arms from anode body with universe mounting.

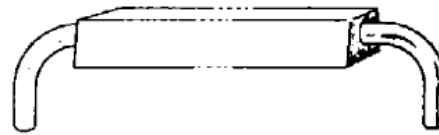

8. Tubular stand-off arms bowed core.

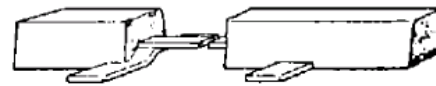

9. strap type core for flush fitting.

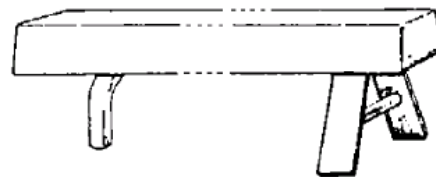

10. Tripod mounting

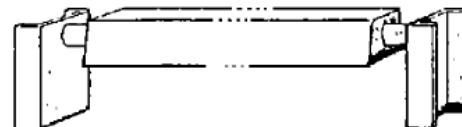

11. standard core stand-off arms with U-section bookends

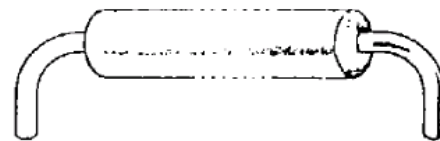

12. cylindrical anode variant of B above.

PART 7**CATHODIC PROTECTION CABLES**

CONTENTS :	PAGE No.
1. SCOPE	107
2. REFERENCES	107
3. DEFINITIONS AND TERMINOLOGY	107
4. UNITS	108
5. TECHNICAL DOCUMENTS	108
6. GENERAL CABLE CONSTRUCTION REQUIREMENTS	109
7. SPECIFIC CABLE REQUIREMENTS	111
8. QUALITY ASSURANCE PROVISIONS	112
9. TESTS	112
10. INSPECTION	113
11. CERTIFICATION	114
12. PACKAGING AND SHIPMENT	114
13. LABELING	114
14. GUARANTEE	115
APPENDICES:	
APPENDIX A DATA SHEET FOR CATHODIC PROTECTION CABLE	116
APPENDIX B DATA SHEET FOR CATHODIC PROTECTION CABLE	117
APPENDIX C DATA SHEET FOR CATHODIC PROTECTION CABLE	118
APPENDIX D DATA SHEET FOR CATHODIC PROTECTION CABLE	119
APPENDIX E CABLE DESIGN DATA	120

1. SCOPE

This part of [IPS-M-TP-750](#) covers the minimum requirements for the materials, construction, dimensions, packaging and tests of cables, intended for DC services in cathodic protection installation for pipelines, well casings, storage tanks, ships and other buried or water-submerged metallic structures.

Appendices A, B, C and D are the data sheets which shall be used for ordering purposes.

2. REFERENCES

Throughout this Standard the following dated and undated standards/codes are referred to. These referenced documents shall, to the extent specified herein, form a part of this standard. For dated references, the edition cited applies. The applicability of changes in dated references that occur after the cited date shall be mutually agreed upon by the Company and the Vendor. For undated references, the latest edition of the referenced documents (including any supplements and amendments) applies.

ASTM (AMERICAN SOCIETY FOR TESTING AND MATERIALS)

B8	Standard Specification for "Concentric-Lay-Stranded Copper Conductors, Hard, Medium Hard or Soft"
D 470	Standard Methods of Testing "Crosslinked Insulations and Jackets for Wire and Cable"
D 1047	Standard Specification for "Poly (Vinyl Chloride) Jacket for Wire and Cable"
D 1351	Standard Specification for "Polyethylene Insulation for Electrical Wire and Cable"
D 2219	Standard Specification for "Poly (Vinyl Chloride) Insulation for Wire and Cable, 60°C Operation"
D 2308	Standard Specification for "Polyethylene Jacket for Electrical Insulated Wire and Cable"
D 2633	Standard Methods of Testing "Thermoplastic Insulations and Jackets for Wire and Cable"
D 2655	Standard Specification for "Crosslinked Polyethylene Insulation for Wire and Cable Rated 0 to 2000 Volts"
D 3144	Standard Specification for "Poly (Vinylidene Fluoride) Heat-Shrinkable Tubing for Electrical Insulation"

IEC (INTERNATIONAL ELECTROTECHNICAL COMMISSION)

IEC 228	"Conductors of Insulated Cable"
---------	---------------------------------

3. DEFINITIONS AND TERMINOLOGY

Conductor

A wire or combination of wires not insulated from one another, suitable for carrying an electric current.

Jacket

An integral covering which is applied over the insulation of a cable and whose prime function is to provide mechanical or environmental protection for the component(s) that it covers.

Primary insulation

The first layer of two or more layers of insulating materials over a conductor. Its prime function is to act as an electrical barrier.

Stranded conductor

A conductor composed of a group of wires, usually twisted, or of any combination of such groups of wires.

Wire

A rod or filament of drawn or rolled metal whose length is great in comparison with the major axis of its cross section.

Inspection and testing terms**Lot**

A lot is any amount of cable of one type and size presented for acceptance at one time.

Sample

A sample is a quantity of production units (reels) selected at random from the lot for the purpose of determining conformance of the lot to the requirements of this Part of Standard specification.

Sample size

The number of production units taken to make up the sample.

Specimen

A specimen is a length of cable removed for test purposes from any individual production unit of the sample.

4. UNITS

This Standard is based on International System of Units (SI), except where otherwise specified.

5. TECHNICAL DOCUMENTS

5.1 The technical bid shall include the following:

- a)** Constructional and electrical data for the cable(s) to be offered.
- b)** Conductor size, number, and diameter of individual strands and overall conductor diameter (mm).
- c)** Thickness of insulation and jacket (mm).

- d) Normal length of cable on reel (m).
- e) Approximate net and shipping weights (kg/km).
- f) Maximum DC resistance at 20°C (ohms/km).

5.2 The Manufacturer shall provide upon request a specification sheet indicating:

- Manufacturer's name.
- Product identification number.
- Construction details.
- Voltage rating of primary insulation.
- Physical properties of the primary insulation and jacket material including tensile strength and ultimate elongation of finished cable, insulation resistance of the primary insulation, notch propagation of the finished cable, abrasion resistance of the finished cable, concentricity tolerance of the finished cable, and continuous service temperature limits of the finished product.
- Test results and test certificates.

6. GENERAL CABLE CONSTRUCTION REQUIREMENTS

6.1 Conductor

The conductors shall be plain annealed stranded copper. Stranding shall be circular (non-compacted).

The material shall be copper of such quality and purity that the finished product shall have the properties and characteristics prescribed in IEC Publication 228 Class 2, or ASTM specification B8 Class B. Conductor sizes, as will be specified by the Purchaser, shall be in accordance with one of the designations listed in Table 1 and/or Appendix E to achieve the resistance value required:

TABLE 1 - CONDUCTOR SIZES

NOMINAL CROSS-SECTIONAL AREA mm ²	MINIMUM NUMBER OF WIRES IN CONDUCTOR	MAXIMUM RESISTANCE OF CONDUCTOR AT 20°C Ω / km
4	7	4.52
6	7	3.02
10	7	1.79
16	7	1.13
25	7	0.712
35	19	0.514
50*	19	0.379
70	19	0.262

* The actual cross-sectional area is approximately 47 mm².

The size, cross-sectional areas, and direct current resistance of the conductor in the completed cable shall conform the minimum and maximum values allowed by the above referenced standards.

6.2 Insulation

6.2.1 General

Cable insulation shall be made from materials chemically and physically resistant to the environmental effects to be anticipated in buried or submerged service. It shall provide continuous coverage, adequate dielectric properties, and have a high resistance to abrasion, stress cracking and notch propagation.

The insulation shall be one of the types listed in subclause 6.2.2. The insulation shall be applied tightly to the conductor without adhering to it and shall form a compact and homogeneous body.

The sheath (jacketing) shall be an extruded layer of the types listed in subclause 6.2.2. The sheath shall be continuous having a thickness as uniform as possible and not less than the values specified. It shall be possible to remove the sheath of the cable without damaging the insulation of the conductor.

Cable insulation (primary insulation and sheath) shall be completely free of cracks, nicks, scratches, or other discontinuities.

Cable insulation shall have a voltage rating of 600/1000 Volts in accordance with National Electrical Code.

6.2.2 Insulating materials

The types of insulation and sheath compound covered by this Part of Standard specification are listed below.

6.2.2.1 Polyvinylchloride (PVC)

Insulation and sheath compound based on polyvinylchloride or copolymer of vinylchloride and vinyl acetate conforming to ASTM specifications D 2219 (as Insulation) and D 1047 (as Jacketing).

6.2.2.2 High molecular weight polyethylene (HMWPE)

Insulation and sheath compound based on thermoplastic polyethylene conforming to ASTM specifications D 1351 (as Insulation) and D 2308 (as Jacketing).

The polyethylene before application to the conductor (or cable) shall comply with the requirements of ASTM specification D 1248 for type I, Class A, B, or C; category 5; grade E 5 or J 3.

6.2.2.3 Cross-Linked polyethylene (XLPE)

Insulation compound based on chemically cross-linked polyethylene conforming to ASTM specification D 2655. The base polymer of this insulation consists substantially of polyethylene or a polyethylene copolymer.

6.2.2.4 Polyvinylidene fluoride (PVDF)

Insulation compound based on specially chemical-resistant modified polyvinylidene fluoride conforming to ASTM specification D 3144.

7. SPECIFIC CABLE REQUIREMENTS

7.1 Positive Conductor Cable

7.1.1 Cable for use as a positive conductor shall be single core, stranded soft annealed copper as per subclause 6.1.

7.1.2 Cable insulation, as will be specified by the Purchaser, shall be either standard or chlorine resistant type and shall conform to one of the following alternatives:

7.1.2.1 Standard type cable

7.1.2.1.1 Cable insulation shall be in accordance with one of the following alternatives, as will be specified by the Purchaser (see Appendix A).

- A single jacket of High Molecular Weight Polyethylene (HMWPE), (see 6.2.2.2).
- A double jacket of High Molecular Weight Polyethylene primary insulation / Polyvinylchloride sheath (see 6.2.2.2 and 6.2.2.1).
- A double jacket of Cross-Linked Polyethylene (XLPE) primary insulation/Polyvinylchloride sheath (see 6.2.2.3 and 6.2.2.1).

7.1.2.1.2 The average thickness of cable insulation shall be 2.8 mm for conductor sizes up to 35 sq. mm and 3 mm for larger sizes. The minimum thickness at any point shall not be less than 90% of the specified average thickness. In case of double jacket the thickness of sheath shall not be less than 1.5 mm.

7.1.2.1.3 Unless otherwise specified by the Purchaser, the color of cable insulation shall be fade-resistant red.

7.1.2.2 Chlorine resistant type cable

(To be used as positive cable in saline water and salty soil ground beds).

7.1.2.2.1 Cable insulation shall be in accordance with one of the following alternatives, as will be specified by the Purchaser (see Appendix B).

- A single jacket of Polyvinylidene Fluoride (PVDF), single or double extruded with the minimum thickness of 0.75 mm. (see 6.2.2.4).
- A double jacket of a radiation cross-linked Polyvinylidene Fluoride primary insulation/High Molecular Weight Polyethylene sheath (minimum thickness $0.5 + 1.7 = 2.2$ mm).

7.1.2.2.2 Unless otherwise specified by the Purchaser, the color of cable insulation shall be fade-resistant red.

7.2 Negative, Bond or Test Conductor Cable

7.2.1 All cables for use as negative conductor, bond conductor, or test conductor shall be single core, stranded soft annealed copper as per subclause 6.1.

7.2.2 Cable insulation (see Appendices C & D), shall be in accordance with one of the following alternatives:

- A single jacket of High Molecular Weight Polyethylene (HMWPE), (see 6.2.2.2).

- A single jacket of Cross-Linked polyethylene (XLPE), (see 6.2.2.3).
- A double jacket of polyvinylchloride primary insulation/polyvinylchloride sheath (see 6.2.2.1).

7.2.3 Minimum thickness of cable insulation shall be 1.0 mm for conductor sizes 6.0 sq. mm or less, 1.5 mm for conductor sizes up to 25 sq. mm and 2 mm for larger sizes.

7.2.4 Unless otherwise specified by the Purchaser, the color of cable insulation shall be fade-resistant black.

8. QUALITY ASSURANCE PROVISIONS

It is the responsibility of the manufacturer to establish quality assurance by quality control procedures which shall ensure that the product will meet the requirements of this Part of Standard specification.

The quality control at the manufacturing plant shall include control systems on the following:

- Raw materials, i.e. checking of documentation and/or testing for conformity with the specification.
- Production equipment and process.
- Testing during and after production (see 9).
- Identification of cables.
- Dimension tolerances.
- Documentation (material certificates).

9. TESTS

9.1 Tests shall be carried out to confirm that the materials comply with this Part of Standard specification and all cables shall satisfactorily pass such tests.

9.2 The factory acceptance tests shall be done on test samples taken from the end of each manufactured length (drum) at a temperature of 20°C and shall cover at least the following:

- Dimensions and construction.
- Dielectric strength of insulation.
- Insulation resistance.
- Electrical resistance of conductor.
- Voltage test.

9.3 All tests shall be carried out in accordance with relevant specifications prescribed in subclauses 6.1 and 6.2.

9.4 Unless otherwise specified in this Part of Standard specification, the methods of sampling and testing shall be in accordance with applicable methods of the International Electrotechnical Commission (IEC), British Standards Institution (BSI), and/or Underwriters Laboratories Inc. (UL) latest edition.

10. INSPECTION

10.1 Responsibility for Inspection

10.1.1 The manufacturer is responsible for the performance of all inspection and tests required by this Part of Standard specification using his own or other reliable facilities and he shall maintain complete records of all such tests and inspections. Such records shall be available for review by the Purchaser.

10.1.2 All tests and inspections shall be made at the place of manufacture. The manufacturer shall afford the inspector representing the Purchaser all reasonable facilities to satisfy him that the material is being furnished in accordance with this Part of Standard specification. Such inspections in no way relieve the manufacturer of his responsibilities under the terms of this Part of Standard specification.

10.1.3 Conformance of the cable to the requirements of this Part of Standard specification shall be determined on samples taken from each lot (see 3) of cable presented for acceptance.

10.1.4 The Purchaser reserves the right to perform any inspections set forth in this Part of Standard specification, where such inspections are deemed necessary to assure that supplies and services conform to the prescribed requirements.

10.1.5 The purchaser's inspector shall have access to the material subject to inspection for the purpose of witnessing the selection of the samples, the preparation of the test samples, and the performance of the test(s). For such tests, the inspector shall have the right to indicate the pieces from which the samples will be taken in accordance with the provisions of this Part of Standard specification.

10.1.6 If any of the samples found not to conform to this Part of Standard specification materials represented by such sample will be rejected.

10.2 General Examination

A visual inspection for the conformity of cables with the requirements specified in this Part of Standard specification and with a good manufacturing practice shall be carried out on cable pieces.

10.3 Conductor Examination

Compliance with the requirements for conductor construction of IEC Publication 228 or ASTM specification B8 shall be checked by inspection. The cross-sectional area shall be checked by measuring the electrical resistance. No measurements of wire diameters shall be required in checking the conductors.

10.4 Thickness of Insulation and Sheath

The thickness of insulation and sheath (if any) shall be checked on a manufacturing length to ensure minimum insulation thickness. The test method shall be in accordance with ASTM methods of testing D 2633 or D 470 complying with the appropriate requirements of Clause 7.

10.5 Insulation Resistance Test

This test shall be made on a single sample per cable type, in accordance with ASTM methods of testing D 2633 or D 470. For standard type cables test shall be carried out by the submerging the sample in pure water. For chlorine resistant type cables this shall be water with an admixture of salt, 30 grams per liter.

11. CERTIFICATION

11.1 The manufacturer's and/or supplier's certification shall be furnished to the Purchaser stating that samples representing each lot have been manufactured, tested, and inspected in accordance with this Part of Standard specification and the requirements have been met.

11.2 The test reports shall contain results of tests required by this Part of Standard specification and other tests specified by the Purchaser.

11.3 Each test report shall be signed by an authorized agent of the seller and/or manufacturer.

11.4 Certified test reports furnished by the manufacturer shall be properly identified with each lot (batch) of products.

12. PACKAGING AND SHIPMENT

12.1 The cables shall be supplied on non-returnable rigid reels in continuous lengths for the cable size involved, with the inner end of cable brought out through the side of the reel(s).

12.2 The cable shall be placed on the reels so that it will be protected from damage during shipment. Each end of the cable shall be firmly and properly secured to the reel. Care shall be taken to prevent looseness of reeled cable.

12.3 The reels shall be lagged or covered with suitable material to provide physical protection for the cables during transit and during ordinary storage and handling operations.

12.4 The manufacturer shall be solely responsible for the adequacy of the preparation for shipping provisions employed with respect to materials and their application to insure that the cable reaches its destination in perfect working condition when handled by commercial carrier systems.

13. LABELING

13.1 Cable Identification

All insulated or jacketed cable shall be durably marked at intervals not exceeding 60 cm with the following minimum information in addition to any standard requirements.

- The maximum working voltage for which the cable was tested or approved.
- The proper designation for the type of cable (positive, negative, chlorine-resistant) and insulation and sheath.
- The manufacturer's name, trademark or other distinctive marking from which the cable manufacturer can be readily identified together with year of manufacture.
- The sq. mm size of conductor.
- The standard to which the conductor conforms (see 6.1).

13.2 Marking of Reels

Each reel and each crate or pallet shall be plainly and durably marked with the following information:

- Name: Cathodic Protection Cable
- Specification: [IPS-M-TP-750](#): Part 7
- Order No.:
- M.E.S.C No.:
- Type of cable: (i.e. positive, negative, bond or test)
- Type of insulation: (i.e. standard or chlorine-resistant)
- Length of cable on reel: (m)
- No., size (mm) and type of conductor:
- Cable configuration:

Thickness (mm) and material of insulation:
Thickness (mm) and material of sheath:
Voltage rating:
Batch No.:
Stock No.:
Date of manufacture:
Quantity of reel on each crate or pallet:
Name or trademark of the supplier:
Manufacturer's name and address:

14. GUARANTEE

Suppliers of cables under this Part of Standard specification shall certify that such cables meet all requirements of this Standard specification, and is of first-class material and workmanship throughout. Suppliers shall replace any length of cables failing under any of the following conditions.

- Under a voltage test after installation, performed before cable is placed in service but within 18 months from date of shipment.
- During normal and proper use within one year of date of commissioning, the commencement of such year being not more than 12 months from date of shipment.

APPENDICES**APPENDIX A
DATA SHEET****(TO BE SUBMITTED BY THE PURCHASER)****FOR****IPS-M-TP-750: Part 7 CATHODIC PROTECTION CABLE**

Positive cable, standard type, single core, 600/1000 Volts, copper conductor, insulated for use as positive conductor in impressed current cathodic protection systems.

The cable shall be in accordance with the latest edition of above Iranian Petroleum Standard with the following specific requirements:

- Project title: - Date:
- Indent No.: - Purchaser:.....
- M.E.S.C No.:
- Length of cable required: meters
- Individual drum length:
- Conductor size: mm²
- Type of insulation: b Single jacket- HMWPE
 b Double jacket- HMWPE/PVC
 b Double jacket- XLPE/HMWPE
- Sheath color:

**APPENDIX B
DATA SHEET****(TO BE SUBMITTED BY THE PURCHASER)****FOR****IPS-M-TP-750: Part 7 CATHODIC PROTECTION CABLE**

Positive cable, chlorine resistant type, single core, 600/1000 Volts, copper conductor, insulated for use as positive conductor in saline water and salty soil ground beds in impressed current cathodic protection systems.

The cable shall be in accordance with the latest edition of above Iranian Petroleum Standard with the following specific requirements:

- Project title: - Date:
- Indent No.: - Purchaser:.....
- M.E.S.C No.:
- Length of cable required: meters
- Individual drum length:
- Conductor size: mm²
- Type of insulation: b Single jacket PVDF
 b Double jacket PVDF/HMWPE
- Sheath color:

**APPENDIX C
DATA SHEET****(TO BE SUBMITTED BY THE PURCHASER)****FOR****IPS-M-TP-750: Part 7****CATHODIC PROTECTION CABLE**

Negative cable, single core, 600/1000 Volts, copper conductor, insulated for use as negative conductor in cathodic protection systems.

The cable shall be in accordance with the latest edition of above Iranian Petroleum Standard with the following specific requirements:

- Project title:
- Date:
- Indent No.:
- Purchaser:.....
- M.E.S.C No.:
- Length of cable required: meters
- Individual drum length:
- Conductor size: mm²
- Type of insulation:
 - b Single jacket- HMWPE
 - b Single jacket - XLPE
 - b Double jacket PVC/PVC
- Sheath color:

**APPENDIX D
DATA SHEET****(TO BE SUBMITTED BY THE PURCHASER)****FOR****IPS-M-TP-750: Part 7****CATHODIC PROTECTION CABLE**

Cable, single core, 600/1000 Volts, copper conductor, insulated for use as bond conductor or test conductor in cathodic protection systems.

The cable shall be in accordance with the latest edition of above Iranian Petroleum Standard with the following specific requirements:

- Project title:
- Date:
- Indent No.:
- Purchaser:.....
- M.E.S.C No.:
- Length of cable required: meters
- Individual drum length:
- Conductor size: mm²
- Type of insulation: b Single jacket - HMWPE
 b Double jacket PVC/PVC
- Sheath color:

**APPENDIX E
CABLE DESIGN DATA**

Cooper conductor	Number of strands	Diameter of strands		Cross sectional Area of conductor (calculated)		Signal conduction Weight per km run kg	Signal conductor Resistance per Meterrun at 20 °C microhm	Typical DC Current ratings (conductor temp, Max.70 °C amp
		inch	mm	sgin	sqmm			
2.5	1		1.78		2.49	22.2	7280	18
	1	0.0808		0.00513	3.31			
4.0	7		0.85		3.972	36.1	4610	24
	1	0.1019		0.00816	5.26			
6.0	7		1.04		5.95	54.0	3080	31
	1	0.1285		0.013	8.37			
10	7		1.35		10.02	90.8	1630	42
	7	0.0612		0.0206	13.3			
16	7		1.70		15.89	145	1150	56
	7	0.0772		0.033	21.14			
25	7		2.14		25.18	229	727	73
	7	0.0867		0.041	26.66			
	7	0.0974		0.052	33.66			
35	19		1.53		34.93	317	524	90
	19	0.0664		0.066	42.45			
50	19		1.78		47.28	429	387	145
	19	0.0745		0.083	53.43			
	19	0.0837		0.1045	67.45			
70	19		2.14		68.34	620	268	185
	19	0.0040		0.132	85.07			
95	19		2.52		94.75	860	193	230
	19	0.0055		0.166	107.76			
120	37		2.03		119.75	1086	153	260
	37	0.0822		0.196	126.58			
150	37		2.25		147.11	1334	124.0	355
	37	0.0900		0.235	151.86			
	37	0.0973		0.275	177.50			
185	37		2.52		184.54	1673	99.1	405
	37	0.1040		0.314	202.78			
240	61		2.25		242.54	2199	75.4	480
	37	0.1162		0.392	253.15			
300	61		2.52		304.2	2759	60.1	560
	61	0.0992		0.471	304.2			
	61	0.1071		0.550	354.5			
	61	0.1109		0.589	380.1			
400	61		2.85		389.1	3528	47.0	680
	61	0.1145		0.628	405.2			
	61	0.1215		0.709	456.3			
500	61		3.20		490.6	4448	36.6	600
	61	0.1280		0.785	506.4			
630	127		2.52		633.4	5744	28.3	910

Note:

Typical current ratings are given as a guide only- always check manufacturer's rating for the particular site operating conditions, including all relevant derating factors.

PART 8**INSULATING JOINT**

CONTENTS :	PAGE No.
1. SCOPE	123
2. REFERENCES	123
3. UNITS	124
4. TECHNICAL DOCUMENTS	124
5. DESIGN	125
6. MATERIALS	126
7. MANUFACTURE	127
8. WELDING REQUIREMENTS	128
9. COATING	128
10. QUALITY ASSURANCE PROVISIONS	129
11. TESTS	129
12. INSPECTION	131
13. TEST CERTIFICATES	132
14. PACKING AND SHIPMENT	132
15. LABELING	133
 APPENDICES:	
APPENDIX A DATA SHEET FOR INSULATING JOINT	134

1. SCOPE

This Part of [IPS-M-TP-750](#) covers the minimum requirements for the design, fabrication and inspection of monolithic insulating joints, for electrical isolation of pipelines from plants and/or other pipelines.

Notes:

1) The purpose of insulating joints is to provide electrical isolation between sections of pipelines to prevent detrimental electrochemical interaction between the sections. Insulating joints are used also to ensure effective current distribution for cathodic protection systems.

2) The insulating joint is intended to be installed under/above ground or above water. It is intended to be girth welded between two pipeline sections.

2. REFERENCES

Throughout this Standard the following dated and undated standards/codes are referred to. These referenced documents shall, to the extent specified herein, form a part of this standard. For dated references, the edition cited applies. The applicability of changes in dated references that occur after the cited date shall be mutually agreed upon by the Company and the Vendor. For undated references, the latest edition of the referenced documents (including any supplements and amendments) applies.

ANSI (AMERICAN NATIONAL STANDARDS INSTITUTE)

- | | |
|--------|--|
| B 16.5 | "Pipe Flanges and Flanged Fittings, Steel Nickel Alloy and Other Special Alloys" |
| B 31.8 | "Gas Transmission and Distribution Piping Systems" |

ASME (AMERICAN SOCIETY OF MECHANICAL ENGINEERS)

- | | |
|---------|---|
| B 16.25 | "Buttwelding Ends"
Boiler and Pressure Vessel Code, Section VIII,
"Rules for Construction of Pressure Vessels", Division 1
Boiler and Pressure Vessel Code, Section IX,
"Qualification Standard for Welding and Brazing Procedures, Welders,
Brazers, and Welding and Brazing Operators"
Boiler and Pressure Vessel Code, Section V,
"Non-Destructive Examination" |
|---------|---|

ASTM (AMERICAN SOCIETY FOR TESTING AND MATERIALS)

- | | |
|-------|--|
| A 105 | Standard specification for
"Forgings, Carbon Steel for Piping Components" |
| A 370 | Standard test method and definitions for
"Mechanical Testing of Steel Products" |
| A 694 | Standard specification for
"Forgings, Carbon and Alloy Steel, for Pipe Flanges, Fittings, Valves and
Parts for High Pressure Transmission Service" |
| D 709 | Standard specification for |

D 2000 "Laminated Thermosetting Materials"
Standard classification system for
"Rubber Products in Automotive Applications"

API (AMERICAN PETROLEUM INSTITUTE)

1104 "Standard for Welding Pipelines and Related Facilities"
5L "Line Pipe"

ISO (INTERNATIONAL ORGANIZATION FOR STANDARDIZATION)

8501-1 "Preparation of Steel Structures Before Application of Paints and Related
Products-Visual Assessment of Surface Cleanliness"
10474 "Steel and Steel Products Inspection Documents"

**MSS (MANUFACTURERS STANDARDIZATION SOCIETY OF THE VALVE AND FITTINGS
INDUSTRY)**

SP-44 "Steel Pipeline Flanges"
SP-75 "Specification for High Wrought Welding Fittings"

BSI (BRITISH STANDARDS INSTITUTION)

BS 5493 Code of practice for
"Protective Coating of Iron and Steel Structures Against Corrosion"

NACE (NATIONAL ASSOCIATION OF CORROSION ENGINEERS)

TM-01-87 "Evaluating Elastomeric Materials in Sour Gas Environments"
MR-01-75 "Material Requirements Sulfide Stress Cracking Resistance-Metallic
Materials for Oilfield Equipment"

3. UNITS

This Standard is based on International System of Units (SI), except where otherwise specified.

4. TECHNICAL DOCUMENTS

The technical bid shall include the following:

- a) Comprehensive catalogues, technical data, general arrangement drawings showing outline dimensions, proposed test procedure, etc. of the offered insulating joint(s).
- b) Detailed drawings showing all parts with material identification and stress/design calculations.
- c) Welding procedure specification.
- d) Material specifications for the following items:
 - Steel forgings
 - Insulating rings
 - Seal Gaskets

- Epoxy resin filler material
- External coating
- Internal coating
- e) Assembly procedure.
- f) Records of tests.
- g) Declaration of confirmation with this Part of Standard specification and/or clear indication of deviations from this Standard specification.
- h) Specification of packing.

5. DESIGN

5.1 All insulating joints shall be of monolithic type fabricated by welding and with pups on either side. The insulating joints shall be suitable for pigging operations.

5.2 The design of the insulating joint(s) shall be compatible with the design code adopted for the pipeline in which it is installed, as stated in the data sheet.

Note:

ANSI/ASME B 31.4 and B 31.8 are commonly adopted pipeline codes. In some situations, e.g. within plant fences, the pipeline sections connected to the insulating joint may be designed to a plant piping code, e.g. ANSI/ASME B 31.3.

5.3 The insulating joint(s) shall be designed so that it's bending moment along with projection pressure to be able to generate a longitudinal stress equal to 75% of the adjacent pipe pups.

5.4 The insulating joint(s) shall be designed following the methodology described in ASME VIII Division 1 Appendix 2 or equivalent, using the design pressure, design temperature and design factor of the pipeline, and the anticipated external loads acting on the insulating joint. Stress due to internal design pressure shall not exceed 50% of specified minimum yield strength of material.

5.5 The insulating joint(s) must be assembled so that its internal components are tightly fixed in the required position. To this purpose an assembling precompression, adequately calculated, shall be applied.

5.6 The number of weldings must be as restricted as possible. All joints shall be butt welded and have full penetration except for the final closure weld. The final closure weld shall be in accordance with ASME Section VIII Div. 1 ULW 17.6.

5.7 For sour service conditions (when specified), the materials shall comply with the requirements of NACE Standards MR 01 75 and TM 01 87.

5.8 Primary and secondary sealing gaskets shall be so designed that the joint assembly complies with the mechanical and electrical requirements specified in this Standard specification. The seal gaskets must oppose the fluid's internal pressure at the same height from the two sides of the rigid insulating ring.

Sealing systems which foresee o-rings cannot be accepted.

The gaskets shall be made of an age resisting elastomer of a high dielectric characteristics. It shall resist explosive decompression, and shall be suitable for long-term exposure to the transported fluid at the design pressure and temperature conditions.

5.9 The insulating materials and filler materials shall be suitable for the long-term exposure to the transported fluid at the design pressure and temperature conditions.

The insulating material shall be non-hygroscopic and shall be of sustaining high compressive stresses. The material shall have good long-term stability, excellent dielectric strength, and thermic

properties without cracking, distorting, or a loss of insulating properties. The material shall be flame resistant, and also resistant to hydrocarbons, sulphides, bacteria and the climatic conditions specified in Appendix A.

5.10 The internal diameter of the joint shall not deviate by more than $\pm 2\%$ from the nominal internal diameter of the pipeline.

5.11 Construction shall not incorporate any flanges, boltings, gaskets, and shall be of rigid and rugged design suitable for field installation without a maintenance pit when installed either on a buried or surface laid pipeline.

5.12 Tension and compression shall be axially transmitted satisfactorily and without appreciable elongation or contraction.

The joint shall indicate no unacceptable deformation when under maximum pressure and temperature.

5.13 The manufacturer shall take into consideration that, during the tie-in to the pipeline, the rings of the rigid insulating material, must not exceed a temperature of 70°C.

5.14 The minimum overall lengths for the joints (as measured between ends) of given size and pressure class shall be as follows:

PIPE SIZE DN	ANSI CLASS RATING					
	150	300	400	600	900	1500
Up to 350	700 mm	700 mm	1000 mm	1000 mm	1000 mm	1000 mm
400 to 600	1000 mm	1000 mm	1200 mm	1500 mm	1500 mm	1500 mm
650 to 900	1500 mm	1500 mm	1800 mm	2000 mm	2000 mm	2000 mm
950 to 1200	2000 mm	2200 mm	2200 mm	2500 mm	2800 mm	2800 mm
1250 to 1500	2500 mm	2800 mm	3000 mm	3000 mm	3200 mm	3200 mm

Note:

For pipelines with a wall thickness exceeding 25 mm, the manufacturer/supplier shall confirm that the length of the joint is suitable for post weld heat treatment of the field welds, i.e. the heat generated by the treatment is not detrimental to the isolating and filler materials and the internal coating. If this is not the case, the length of the joint shall be increased accordingly.

6. MATERIALS

6.1 Material for the pressure containing parts of the insulating joints shall meet the requirements of data sheet (see Appendix A).

The metallic parts of the insulating joint shall be of forged¹⁾ steel conforming to the requirements of MSS-SP-44.

6.1.1 The ladle analysis of each heat of steel used in the manufacture of insulating joint shall conform to the material degree that is declared to be used with the restrictions foreseen by Para. 6.1.2.

1) Forged, fully killed, normalized or hardened and tempered materials will have to be used according to the schedule here below:

APPROVED STUB MATERIAL

- API 5L Gr. A
- API 5L Gr. B

FORGED MATERIAL

- ASTM A 105
- ASTM A 105

API 5L x 42	ASTM A 694 F 42 or F 52
API 5L x 52	ASTM A 694 F 52
API 5L x 60	ASTM A 694 F 60
API 5L x 65	ASTM A 694 F 65

6.1.2 The carbon equivalent calculated with the following formula shall not exceed 0.42%:

- C.E. = $C + Mn/6$
- C.E. = Carbon Equivalent
- C = Carbon
- Mn = Manganese

Materials, quality and size of the pups shall be the same as or better than those of the pipe to be connected (see data sheet).

6.2 Insulating materials shall be made of age resisting laminated epoxy resin reinforced with glass fiber conforming to ASTM specification D 709 Type IV Group G 10/G 11 or equivalent standard.

6.3 The primary and secondary sealing gaskets shall be made of fluorinated elastomers like PTFE and/or Butadieneacrylonitrile copolymers like Nitrile rubber according to ASTM specification D 2000, or equivalent standard.

6.4 Filling materials shall be of adhesive sealant elastomer having a compressive strength greater than 1500 kg/cm².

7. MANUFACTURE

7.1 The manufacturer shall be responsible for the integrity of the manufacturing procedures and adherence to this Part of Standard specification.

7.2 The assembly of insulating joint(s) shall be done in a controlled, clean environment.

7.3 The insulating joint(s) shall be assembled in such a way that its various components are firmly locked in position and the complete joint is capable of withstanding stresses due to designed operating conditions and field hydrostatic testing.

7.4 The surface of the annular space between the pup and the retainer shall be abrasive shot-blasted to SA 2½ grade in accordance with ISO 8501-1. Assembly of the insulating joint shall commence within 2 hours after completion of abrasive shot blasting.

7.5 The annular space between the retainer and the pup shall be filled with an epoxy resin filler material; to be approved by the Purchaser’s representative.

7.6 Any depressions in the insulating joint shall be filled with adhesive sealant elastomer to prevent the deposition of sediment at this point.

7.7 Insulating joint(s) shall not be of harmful defect specified on para. 14.5.2 of MSS-SP-75 and the other defects in surface shall be removed according to Para. 14.5.3 of MSS-SP-75.

7.8 All butt welds shall be heat treated after all welding has been completed in accordance with the requirements of ASME Boiler and Pressure Vessel Code, Section VIII.

7.8.1 Lamination found at the bevel end parts shall be removed wholly.

7.8.2 The height of internal weld beads shall be less than 2 mm.

7.8.3 Under-cutting on weld seam shall not be permitted.

7.9 The end connections shall be beveled for welding in accordance with MSS-SP-75, unless otherwise specified by the Purchaser, to allow welding to the pipeline with only two circumferential butt welds. Welding bevels shall be dry and free from grease and other contaminants.

7.10 For a distance of 100 mm from the welding ends, the internal diameter shall not deviate by more than ± 1.5 mm from the nominal internal diameter of the pipeline.

7.11 Heat-treatment for insulating joint(s) shall be performed according to ASME VIII, Division I and related ASME specification.

In this case, the temperature in furnace shall be recorded and controlled continuously during processing, and record chart shall be submitted to purchaser. When required, before manufacturing, supplier shall submit the heat treatment specification described following items:

- Heat-treatment procedure.
- Standard temperature curve chart.
- Temperature control range.

8. WELDING REQUIREMENTS

8.1 Approved Welding Processes

Any of the following processes may be used:

- a) Shielded Metal Arc Welding (SMAW).
- b) Gas Tungsten-Arc Welding (GTAW or TIG).
- c) Gas Metal-Arc Welding (GMAW, or MIG).
- d) Submerged Arc Welding (SAW).
- e) Combinations of above processes.

8.2 Procedure Qualifications

Welding procedures shall be qualified in accordance with ASME Section IX.

8.3 Welder Qualifications

Welders shall be qualified in accordance with the requirements of ASME Section IX.

8.4 Consumable Materials

Electrodes, filler wires and fluxes shall conform to AWS specifications A 5.1 through A 5.30 as applicable.

8.5 Weld Details

All joints shall be butt-welded and have full penetration welds except for the final closure weld, which shall be welded in accordance with ASME VIII ULW 17.6, Fig. "A".

9. COATING

After all tests and inspections required have been carried out, insulating joints shall be thoroughly cleaned in order to remove rust or impurities. Surface preparation shall be carried out by shot blasting or sand blasting to SA 2½ grade in accordance with ISO 8501-1. After visual inspection, all insulating joints shall be externally and internally coated with an amine cured epoxy paint to a dry film thickness of 500 microns applied in two coats. The application shall be in strict accordance with the coating supplier's specification. Beveled ends for 50 mm approx. shall be painted with rust preventive paint.

Note:

Epoxy internal coatings may not be suitable for some chemical products. When other coatings need to be specified, advice from a material specialist should be taken. Metallic pigmented coatings shall not be used.

The coatings shall be subject to holiday detection using a wet sponge tester set at 60 volts. The acceptance level shall be zero pinholes.

10. QUALITY ASSURANCE PROVISIONS

It is the responsibility of the manufacturer to establish quality assurance by quality control procedures which shall ensure that the product will meet the requirements of this Part of Standard specification.

The quality control at the manufacturing plant shall include control systems on the following:

- Raw materials, i.e. checking of documentation and/or testing for conformity with the specification.
- Production equipment and process.
- Testing during and after fabrication.
- Checking of dimensions.
- Documentation (material certificates).

As alternative to above control system the manufacturer can have quality assurance system in accordance with ISO 9002.

11. TESTS

11.1 General

Tests shall be carried out to conform that the materials comply with this Part of Standard specification and all insulating joints shall satisfactorily pass such tests.

11.2 Items of Test and Inspection

TEST ITEM	MANUFACTURER	PURCHASER WITNESS	RECORD
Chemical analysis	0	*	0
Mechanical test	0	*	0
Hydraulic test or air tightness test	0	0	0
Radiographic test	0	*	0
Coating inspection	0	*	0
Dielectric test & megger test	0	0	0
Ultrasonic test & magnetic particle test	0	*	0
Dye penetration test	0	*	0
Visual inspection	0	0	0
Dimension check	0	0	0
Heat treatment	0	*	0

Legend:

- 0 : Operation & record
- * : Document check

11.3 Chemical Analysis

Chemical analysis shall be performed by the ladle analysis for each heat of steel used and shall conform to the requirements of the chemical composition for the respective materials as per relevant standard.

11.4 Mechanical Test

Tensile test is performed for each lot after heat-treatment.

The same charged, shaped and heat-treated products are considered 1 lot.

1) Forgings

The tensile tests shall be performed according to ASTM A 370 code corresponding to equivalent material and the results shall comply with the mechanical requirements in this Part of Standard specification.

2) Pups

The tensile tests shall be performed according to Section 3, Mechanical Properties and Tests of API 5L. No leakage or pressure drops shall be permitted during the test.

11.5 Dielectric Test and Megger Test

Upon completion of the assembly and prior to the hydrostatic test, each insulating joint shall be megger tested with 1000 V. d.c. Minimum resistance shall be 25 Meg ohms.

Each insulating joint shall also be dielectric tested at 5000 V. a.c. (50 Hz) for 1 minute. There shall be no corona effects or breakdown.

The above stated tests shall be repeated after hydrostatic test. The readings before and after the hydrostatic test shall be equal.

11.6 Hydrostatic Test

The insulating joint shall be hydrostatically tested, in an unrestrained condition, using water with a low surface tension, at 1.5 times the rating (permissible working pressure).

In the test, the insulating joint shall be subjected to the full axial load deriving from the hydrostatic pressure unless it has been verified in a type test that the insulating joint is able to resist the full axial load in service.

Unless otherwise specified by the Purchaser the maximum test pressure shall be maintained for at least three hours. No leaks or unacceptable deformation shall occur during the test.

11.7 Low Pressure Leakage Test (Air Test)

After hydrostatic test, a low pressure leakage test shall be carried out on each insulating joint. The joint shall be filled with air and will be pressurized to 0.5 MPa and held at that pressure for 10 minutes. No leakage or pressure drops shall be permitted during the test.

11.8 Prototype Tests

Prototype tests shall be required if the manufacturer can not provide data of similar tests to the satisfaction of the Purchaser.

Prototype joints, representative of production, selected for test shall be identified as to material, grade, and lot, including heat treatment, hydrostatic cyclic pressure tests, hydrostatic pressure plus bending test, and vacuum test where appropriate.

11.9 Radiographic Test

All butt welds shall be 100% radiographed by X-ray in accordance with Section V of the ASME Boiler and Pressure Vessel Code Non-destructive Examination.

11.10 Magnetic Particle and Ultrasonic Test

11.10.1 The final closure weld shall be inspected by ultrasonic or magnetic particle methods in accordance with ASME Section VIII.

11.10.2 All finished bevel ends shall be 100% ultrasonically tested for lamination type defects for a distance of 50 mm from the ends. Lamination shall not be acceptable.

Notes:

1) The ultrasonic examination method shall be applied before preparing weld edges, especially for areas of 25 mm width around the edge.

2) The magnetic particle examination shall be made only after completion of weld edge preparation.

11.10.3 Acceptance criteria shall be as per ASME Sec. VIII Div. I, Appendix 12.

11.11 Dye Penetrant Test

Dye penetrant test shall be performed on the machined surface according to ASME Section VIII, DIV. I. Appendix 8.

11.12 Visual Inspection and Dimensional Check

11.12.1 Visual inspection of all parts prior to assembly and after finishing of the insulating joint shall be carried out by the manufacturer. General appearance shall show good workmanship.

11.12.2 Dimensions of the insulating joint(s) shall be checked against the specifications, purchase order description and/or approved manufacturer drawings.

11.12.3 The inside and outside thickness of coating shall be checked and it shall not be below the values indicated in Clause 9. The coating appearance shall be even on the whole surface.

12. INSPECTION

12.1 The manufacturer/supplier shall be responsible for carrying out all the tests and inspections required by Part 8 of this Standard specification, using his own or other reliable facilities, and he shall maintain complete records of all such tests and inspections. Such records shall be available for review by the Purchaser. Certified tests and inspection reports shall be properly identified with each batch (lot) of product. The manufacturer shall afford the Purchaser's inspector all reasonable facilities necessary to satisfy him that the insulating joint(s) are fabricated in accordance with the provisions of this Part of Standard specification.

12.2 The Purchaser reserves the right to perform any inspections set forth in this Part of Standard specification where such inspections are deemed necessary to assure that supplies and services conform to the prescribed requirements.

12.3 If the Purchaser desires that his representative inspect or witness the inspection and testing of the product prior to shipment, the manufacturer/supplier shall afford the Purchaser's representative

all reasonable facilities to satisfy him that the product meets the requirements of this Specification. Such inspections in no way relieve the manufacturer/ supplier of his responsibilities under the term of this Part of Standard specification.

12.4 Purchaser's inspector(s) shall have free access to the manufacturer's works to follow up the progress of the materials covered by this Part of Standard specification and to check the quality of materials. The manufacturer/supplier shall place free of charge at the disposal of the Purchaser's inspector(s) all means necessary for carrying out their inspection: results of tests, checking of conformity of materials with this Standard requirements, checking of marking and packing and temporary acceptance of materials.

12.5 An inspection certificate shall be provided by the manufacturer in accordance with the following:

- ISO 10474 Type 5.1.B for chemical analysis, mechanical properties, notch toughness properties, hardness properties, heat treatment, non-destructive examination.
- ISO 10474 Type 5.1.C for other tests, e.g. dimensional checks, pressure test (when specified), functional checks.

12.6 The insulating joints may be rejected if measurement, inspection and/or testing reveal discrepancies between quoted figures resulting in purchase order documents (including this Part of Standard specification and its attachments), and those obtained actually.

13. TEST CERTIFICATES

The manufacturer/supplier shall submit following certificates, as a minimum:

- a) Test certificates relevant to the chemical and mechanical properties of the materials used for construction as per this Part of Standard specification and relevant standards.
- b) Test reports for radiographic and ultrasonic inspection and dye penetration tests.
- c) Test certificates for hydrostatic and air tests.
- d) Test certificate for electrical tests.
- e) Stress relieve and heat treatment certificates.
- f) Test certificate for dimensions and sectional drawings.

In addition to the certified material test reports the manufacturer/supplier shall provide a user manual detailing the requirements for installation and inspection in service.

The certificates shall be considered valid only when signed by Purchaser's inspector.

14. PACKING AND SHIPMENT

14.1 Both ends of each insulating joint shall be closed with slip-on recessed end caps to protect the internal parts and also the beveled ends from any possible damage. Care shall be taken to prevent damage to the external and internal coatings.

14.2 Insulating joints shall be suitably packed and protected against all damages or defects which may occur during transit (sea shipment to the port and rough road haulage to site), and extended tropical open air storage up to 24 months.

Note:

Tack welding of protectors to the joints is not permitted.

14.3 Only those insulating joints which have been inspected and certified by Purchaser's inspector shall be shipped.

15. LABELING

15.1 Marking of Insulating Joints

All insulating joints furnished under this Part of Standard specification shall be clearly identified with the information marked with low stress die stamps or interrupted dot stamps on the outside of each completed insulating joint as follows:

- a) Manufacturer's name;
- b) joint serial No.;
- c) size (DN);
- d) thickness of ends;
- e) material grade;
- f) ANSI rating;
- g) maximum working temperature rating, in °C;
- h) the year of manufacturing;
- i) tag No.;
- j) weight.

Note:

When sour service conditions are specified, the insulating joint shall be stamped "NACE MR 0175".

15.2 Marking of Container

Each container of insulating joint(s) shall be marked with the following information:

- Name: Insulating joint.....
- Specification: [IPS-M-TP-750](#): Part 8.....
- Order No.:
- M.E.S.C No.:
- Joint serial No.:
- Size (DN):
- Thickness of ends:
- Material grade:
- ANSI rating:
- Weight:.....
- Temperature rating, in °C:
- Batch No.:
- Stock No.:
- Date of manufacture:
- Quantity:
- Trademark of the manufacturer:.....
- Manufacturer's name and address:.....

APPENDICES

**APPENDIX A
DATA SHEET**

**(TO BE SUBMITTED BY THE PURCHASER)
FOR
INSULATING JOINT**

Project title: Indent No.: Date: Quantity:	Purchaser: b Oil industry b Gas industry b Petrochemical industry
ITEM	SELECTION
Pipeline design code	b ANSI B 31.4 b ANSI B 31.8 b Other:
Pipeline design factor	
Pipeline outside diameter	mm
Pipeline wall thickness	mm
Pipeline material	Specification: Type/grade:
Pipeline design pressure	bar (ga)
Pipeline design temperature	Minimum: °C Maximum: °C
Transported fluid	
Insulating joint length	mm
Sour services	b Yes b No
Toxic services	b Yes b No
Installation	b Buried b Overground b Offshore
ADDITIONAL DATA	
Made by: Checked by: Approved by:	Date: Date: Date:

PART 9**FLANGE INSULATION KIT**

CONTENTS :	PAGE No.
1. SCOPE	137
2. REFERENCES	137
3. DEFINITIONS AND TERMINOLOGY	137
4. UNITS	137
5. TECHNICAL DOCUMENTS	137
6. GENERAL DESCRIPTION	138
7. MATERIALS	138
8. REQUIREMENTS	139
9. PACKAGING	141
10. QUALITY ASSURANCE PROVISIONS	141
11. SAMPLING	142
12. INSPECTION AND TESTING	142
13. LABELING	143
 APPENDICES:	
 APPENDIX A DATA SHEET FOR FLANGE INSULATION KIT	144

1. SCOPE

This Part of [IPS-M-TP-750](#) covers the minimum requirements for flange insulation kit, complete, intended for electrical insulation of standard, flat face, raised face, or ring joint type, flanges used for cathodically protected steel pipes and forming part of corrosion protection of the structure.

Appendix A is the data sheet which shall be used for ordering Purposes.

2. REFERENCES

Throughout this Standard the following dated and undated standards/codes are referred to. These referenced documents shall, to the extent specified herein, form a part of this standard. For dated references, the edition cited applies. The applicability of changes in dated references that occur after the cited date shall be mutually agreed upon by the Company and the Vendor. For undated references, the latest edition of the referenced documents (including any supplements and amendments) applies.

ASME (AMERICAN SOCIETY OF MECHANICAL ENGINEERS)

B 16.5	"Pipe Flanges and Flanged Fittings, Steel Nickel Alloy and Other Special Alloys"
B 16.20	"Ring-Joint Gaskets and Grooves for Steel Pipe Flanges"
B 16.21	"Non-Metallic Flat Gaskets for Pipe Flanges"

ASTM (AMERICAN SOCIETY FOR TESTING AND MATERIALS)

D 709	Standard Specification for "Laminated Thermosetting Materials"
D 229	Standard Methods of Testing "Rigid Sheet and Plate Materials Used for Electrical Insulation"
D 883	"Standard Definitions of Terms Relating to Plastics"
F 118	"Standard Definitions of Terms Relating to Gaskets"
D 4088	Standard Practice for "Preparation for Shipment of Solid Electrical Insulating Materials"

US MILITARY SPECIFICATION

MIL-P-15035	"Plastic Sheet; Laminated, Thermosetting, Cotton-Fabric-Base, Phenolic-Resin"
-------------	---

3. DEFINITIONS AND TERMINOLOGY

For definitions of technical terms pertaining to gaskets and plastics used in this Part of Standard specification see ASTM D 883 and F 118.

4. UNITS

This Standard is based on International System of Units (SI), except where otherwise specified.

5. TECHNICAL DOCUMENTS

The technical bid shall include the following:

- a) Manufacturing specification and procedure.
- b) Catalogue showing materials, dimensions, and configuration.

- c) Material specification for the components to be offered.
- d) Test specification and procedure.
- e) Specification of packing.

6. GENERAL DESCRIPTION

6.1 Each kit shall include the following components:

- a) Insulating central gasket
- b) Insulating bolt sleeves
- c) Insulating bolt washers
- d) Steel bolt washers

Note:

The insulating sleeve and washer may be supplied as one-piece.

6.2 Gaskets shall be manufactured from material having low water absorption and high compressive strength. Preference shall be given to materials with low y and m factors. The y factor is a measure of the compressive load required to establish an initial seal, while the m factor is an indication of the additional load required to hold the fluid pressure needed to keep the seal in operation. The smaller these factors are, the less bolt loading is required.

Gasket materials shall withstand the expected bolt loading without injurious crushing, and which are suitable for the service conditions. It shall not crack or distort under load and shall be unaffected by salt water, hydrocarbons, natural gas, sunlight or atmospheric conditions.

Note:

The m and y factors for various materials are included in the ASME Code, Section VIII and ASME B 16.5.

6.3 Insulating bolt sleeves shall be manufactured from materials having low water absorption, high dielectric strength, and low cold-flow characteristics. They shall be suitable for the service conditions of the particular application.

6.4 Insulating washers shall be manufactured from materials having high compressive strength, low water absorption, high dielectric strength, and low cold-flow characteristics.

7. MATERIALS

7.1 The central gasket for flat face or raised face flanges shall be made of a fabric-reinforced phenolic laminate core material ¹⁾ coated on both sides with a chloroprene polymer (i.e. neoprene) sheets.

7.2 The central gasket for ring joint flanges shall be made from fabric-reinforced phenolic laminate core material ¹⁾.

7.3 Insulating sleeves shall be fabricated from high density polyethylene material, to which shall be added only those antioxidants, UV stabilizers and pigments necessary for the manufacture of sleeves to the specification and to its end use.

¹⁾ The fabric-reinforced phenolic laminated core material shall consist of a suitable cotton fabric base or filler properly impregnated and bonded with a phenolic thermosetting resin compound or binder, processed to meet the requirements of this Part of Standard specification, which meet US Military Specification MIL-P-15035 Type F.B.G or ASTM D 709 Type II Grade CE.

Notes:

- 1) The choice of stabilizers and other additives is at the discretion of the manufacturer.
- 2) Moulding compounds of unknown composition shall not be used. Impurities which are occasionally contained in polymers shall not exceed 0.1% by mass.

7.4 Insulating washers, except when cast integrally with sleeves, shall be fabricated from fabric-reinforced phenolic material and shall be 3.2 mm thickness (nominal).

7.5 Combined insulating sleeve/insulating washer shall be fabricated from injection molded acetal copolymer or equivalent in the form of a one-piece casting.

7.6 Steel washers shall be fabricated from plated mild steel as per BS-3410 (Table 7), 3.2 mm thickness, and shall be treated to prevent corrosion.

8. REQUIREMENTS

8.1 Dimensions

8.1.1 Unless otherwise specified by the Purchaser, gaskets for flat face or raised face flanges shall conform to the dimensions specified in ANSI B 16.21. They shall have a nominal thickness of 3.2 mm and protrude into the bore of the pipe by 1.5 mm to prevent electrically conductive bridging over the insulation by debris, etc.

8.1.2 Ring gaskets for ring-joint flanges shall be of dimensions established in ANSI B 16.20. Sheet and ring joint gaskets for sizes NPS 10 and smaller shall conform to ANSI B 16.5 dimensions and recommendations.

8.1.3 Insulating bolt sleeves are normally designed for standard bolting in standard bolt holes and shall be of sufficient length to extend halfway inside the steel washer. Care shall be taken to ensure that the dimensions selected will allow the use of the standard size bolt or one size smaller high tensile strength bolt.

8.1.4 Insulating bolt washers shall be sized internally so that the bolt sleeve will pass through, and the OD shall be sized so that the washer will fit inside the flange spot facing.

8.1.5 Steel washers shall be the same size as the insulating washer.

8.2 Uniformity

The materials shall be uniform in texture, finish, and specified properties.

8.3 Surface Defects

The materials shall be free from blisters, wrinkles, air marks, or cracks, and reasonably free from other small defects such as scratches, dents, heat marks, etc.

8.4 Workmanship

All materials and workmanship shall be in accordance with good commercial practice, and the

resulting products shall be free from porous areas, air pockets, foreign matter, or other defects affecting serviceability.

8.5 Detail Requirements for Insulating Gaskets and Sleeves

8.5.1 Gaskets

8.5.1.1 Type

The type of insulating gaskets provided for herein which are suitable for use with the flange facing indicated are as follows:

<u>Gasket Type</u>	<u>Flange Facing</u>
Full face	Flat face or raised face
Self-centering flat ring	Raised face
Ring joint (oval or octagonal)	Ring-joint

8.5.1.2 Sizes

The gasket nominal size, shall be the same as used on the standard pipe flanges and flange fittings in accordance with ANSI B 16.21 and/or ANSI B 16.20.

8.5.1.3 Property values

Gasket materials shall conform to the requirements for physical and electrical properties prescribed in Table 1.

8.5.1.4 Machinability

The material shall be such that it can be drilled, tapped, sawed, and machined in all directions ¹⁾ in accordance with the manufacturer's recommended technique without cracking, splitting, or otherwise impairing the material for general use.

TABLE 1 - PROPERTIES OF INSULATING GASKET MATERIALS

CHARACTERISTIC	UNIT	REQUIREMENT	TEST METHOD ASTM
Thickness (nominal)	mm	3.2 ±0.15	D 229
Flexural strength, Flatwise: (min.) LW CW	MPa	115 95	D 229
Impact strength, (Izod, edgewise): (min.) LW CW	j/m of notch	86.4 75.6	D 229
Dielectric breakdown parallel to laminations (step by step test), (min.)	Kv	25	D 229
Dielectric strength perpendicular to laminations (step by step test), (min.)	kV/mm	8	D 229
Water absorption (max.)	%	1	D 229

LW: Tested in a lengthwise direction.

CW: Tested in a crosswise direction.

1) The nature of laminated materials necessitates special precaution when drilling and tapping parallel to laminations.

8.5.2 Sleeves

The insulating sleeves shall be made of high density polyethylene (see 7.3) and shall meet the requirements of Table 2.

TABLE 2 - PROPERTIES OF INSULATING SLEEVES

CHARACTERISTIC	UNIT	REQUIREMENT	TEST METHOD ASTM
Material	---	Polyethylene	---
Density (min.)	g/cm ³	0.941	D 1505
Thickness (nominal)	mm	0.8	D 374
Dielectric strength (min.)	kV/mm	16	D 149
Water absorption (max.)	%	0.01	D 570
Tensile strength (min.)	MPa	19	D 638

9. PACKAGING

The kits purchased according to this Part of Standard specification shall be packaged in suitable containers to ensure acceptance and safe delivery to their destination. Individual kits shall be packaged in such a manner as to protect the material against physical and mechanical damage and contamination during shipment, handling and storage. Each container shall contain application instructions. All packaging and packing provisions of ASTM practice D 4088 shall apply to this Part of Standard specification.

10. QUALITY ASSURANCE PROVISIONS

10.1 It is the responsibility of the manufacturer to establish quality assurance by quality control

procedures which shall ensure that the product will meet the requirements of this Part of Standard specification.

10.2 The quality control at the manufacturing plant shall include control systems on the following:

- Raw materials, i.e. checking of documentation and/or testing for conformity with the specification.
- Production equipment and process.
- Testing during and after production.
- Identification of materials.
- Checking of dimensions.
- Documentation (material certificates).

11. SAMPLING

11.1 Lot

The lot or batch shall consist of an indefinite number of finished products offered for acceptance, of materials manufactured by a single plant run through the same processing equipment, with no change in ingredient materials.

11.2 Unless otherwise specified by Purchaser, the number of samples for inspection and/or testing shall consist of 10 percent of the lot, but in no case shall be less than one or more than ten kits.

11.3 Sampling shall be in accordance with the ASTM test methods for the specific properties to be determined.

11.4 The numbers and types of test specimens shall be in accordance with the ASTM test method for the specific properties to be determined.

12. INSPECTION AND TESTING

12.1 All tests and inspections shall be made at the place of manufacture prior to shipment. The manufacturer shall be responsible for carrying out all the tests and inspections required by this Part of Standard specification.

12.2 The manufacturer/supplier shall provide the Purchaser, without charge, all reasonable facilities to satisfy him that the material is being furnished in accordance with this Part of Standard specification.

12.3 Samples of any or all ingredients used in the manufacture of this material may be requested by the Purchaser and shall be supplied upon request, along with the supplier's name and identification for the sample.

12.4 Purchaser's inspector(s) shall have free access to the manufacturer's work to follow up the progress of the materials covered by this Part of Standard specification and to check the quality of materials. The manufacturer/supplier shall place free of charge at the disposal of the purchaser's inspector(s) all means necessary for carrying out their inspection : results of tests, checking of conformity of materials with this Standard requirements and checking of marking and packing.

12.5 Samples submitted to the Purchaser and/or collected by the Purchaser will be tested in the Purchaser's laboratory or in a responsible commercial laboratory including manufacturer's laboratory designated by the Purchaser.

12.6 The manufacturer/supplier shall furnish the Purchaser with a certified copy of results of tests made by the manufacturer covering physical and performance characteristics of each batch of product to be supplied under this Part of Standard specification. The manufacturer/supplier shall furnish, or allow the Purchaser to collect samples of the material representative of each batch of product. Certified test reports and samples furnished by the manufacturer/supplier shall be properly

identified with each batch of product.

12.7 Prior to acceptance of the supplier's and/or manufacturer's materials, samples of material submitted by the supplier, or collected by the Purchaser, will be tested by the Purchaser. If any of the samples is found not to conform to this Part of Standard, materials represented by such sample will be rejected. If samples of the supplier's and/or manufacturer's material that have been previously accepted are found not to conform to this Standard, all such material will be rejected.

13. LABELING

13.1 Marking of Gaskets

Each gasket shall be marked with the clearly legible letters not exceeding 6.35 mm in height. These markings shall include the gasket manufacturer's name or symbol, the flange size and class, the year of manufacture, and Purchaser's name and order No.

13.2 Marking of Containers

Each container shall be marked with the following information:

- Name: Flange insulation kit
- Specification: [IPS-M-TP-750](#): Part 9.....
- Order No.:
- M.E.S.C No.:
- Type of gasket:
- Gasket nominal diameter:
- Pressure rating:
- Temperature rating:
- Batch No.:
- Stock No.:
- Date of manufacture:
- Quantity:
- Storage condition:
- Manufacturer's name and address:.....

APPENDICES

APPENDIX A

DATA SHEET

(TO BE SUBMITTED BY THE PURCHASER)

FOR

FLANGE INSULATION KIT

Project		Quantity :	
Indent No:		Pipe size (DN) :	
Date :		Pipe wall thickness : mm	
		Flange standard :	
PURCHASER		INSTALLATION	
<input type="checkbox"/> Oil industry <input type="checkbox"/> Gas industry <input type="checkbox"/> petrochemical industry		<input type="checkbox"/> pipeline <input type="checkbox"/> plant	<input type="checkbox"/> liquid <input type="checkbox"/> Gas <input type="checkbox"/> Buried <input type="checkbox"/> overground <input type="checkbox"/> oil shore
SERVICE CONDITIONS		OPERATING CONDITIONS	
SITE CONDITIONS	ATMOSPHERE	FLUID TYPE	OPERATING PARAMETERS
	Solferous <input type="checkbox"/> Dusty <input type="checkbox"/> Corrosive <input type="checkbox"/> Occasional storm <input type="checkbox"/>	Fluid: Corrosive <input type="checkbox"/> Errusive <input type="checkbox"/> Toxic <input type="checkbox"/>	Pressure Max. barg Min. barg Temperature Max °C Min °C
AV. Min. temp: °C AV. Max. temp: °C			
Max . Ret . Humidity			ANSI rating PN
CASKET TYPE	SLEEVE TYPE	WASHERS	
<input type="checkbox"/> Full face <input type="checkbox"/> Self_centering flat ring <input type="checkbox"/> Ring joint : <input type="checkbox"/> Basic oval <input type="checkbox"/> octagonal	<input type="checkbox"/> Full length <input type="checkbox"/> Half length <input type="checkbox"/> Integral sleeves and washers	<input type="checkbox"/> SW- signal washer set <input type="checkbox"/> DN – double washer set	

PART 10**POLYPROPYLENE ROPE**

CONTENTS :**PAGE No.**

1. SCOPE	147
2. REFERENCES	147
3. UNITS	147
4. TECHNICAL DOCUMENTS	147
5. REQUIREMENTS	147
6. QUALITY ASSURANCE PROVISIONS	149
7. INSPECTION AND TESTING	150
8. CERTIFICATION	150
9. PACKAGING AND DELIVERED LENGTH	151
10. MARKING	151
11. LABELING	151

1. SCOPE

This Part of [IPS-M-TP-750](#) covers the minimum requirements for 3-strand (hawser laid) rope made of polypropylene for use in dry and water type deep well groundbeds.

2. REFERENCES

Throughout this Standard the following standards and codes are referred to. The editions of these standards and codes that are in effect at the time of publication of this Standard shall, to the extent specified herein, form a part of this Standard. The applicability of changes in standards and codes that occur after the date of this Standard shall be mutually agreed upon by the Company and the Vendor.

ASTM (AMERICAN SOCIETY FOR TESTING AND MATERIALS)

D 543 Standard test method for "Resistance of Plastics to chemical Reagents"

ISO (INTERNATIONAL ORGANIZATION FOR STANDARDIZATION)

ISO 2307 "Ropes-Determination of Certain Physical and Mechanical Properties"

3. UNITS

This Standard is based on International System of Units (SI), except where otherwise specified.

4. TECHNICAL DOCUMENTS

The technical bid shall include the following:

- a) Catalogue.
- b) Rope size, quantity (net and gross mass), material and construction.
- c) Main characteristics and tolerances.
- d) Production procedures that covers all stages of the manufacturing process, from receipt of raw materials to finishing and packing for shipment, including:
 - Measurement of diameter, weight, etc.
 - Inspection and testing procedure, including acceptance criteria, and frequencies.
 - Rope manufacture.

5. REQUIREMENTS

5.1 Material and Manufacture

Only virgin polymeric material shall be used. The polymeric material used in manufacturing the rope shall be homopolymers or copolymers of polypropylene processed as continuous multi-filament, having a relative density of approximately 0.91 to produce rope having the characteristics specified in Table 1. The rope shall be stabilized against deterioration due to sunlight by the addition to the polymer of an additive or additives.

Note:

Any Ultra-Violet (UV) inhibiting system may be used, such as pigmentation using carbon black, Iron (III) oxide (Fe_2O_3) or any other coloring product or special UV inhibitor.

It shall be resistant to sodium chloride solution when tested in accordance with ASTM method D 543.

5.2 Flexibility and Uniformity of Strands

The finished rope shall be flexible and shall consist of uniform strands, well laid and as free as practicable from defects in the yarn, strand and finishing.

5.3 Linear Density

The rope shall have a linear density (net mass, in grams per meter) given in Table 1, measured when the rope is subjected to the tension called the reference tension, within a tolerance of $\pm 10\%$.

Note:

Reference tension to be applied to the rope, conforming to this Part of Standard specification, when measuring linear density and lay shall have the nominal value of 8 daN (deca newton) within a tolerance of $\pm 5\%$.

5.4 Diameter

The diameter of rope shall vary by not more than $\pm 4\%$ from that specified in Table 1, measured at zero tension.

5.5 Securing Rope Ends

The ends of the rope shall be secured to prevent unlaying.

5.6 Finish

Weighting and loading materials shall not be added.

5.7 Yarn in the Strands

Each strand shall consist of a sufficient and equal number of rope yarns to produce a rope which shall comply with the requirements given in Table 1. The rope yarns shall not contain fibers which have been used or recovered.

5.8 Structure

The rope and their strands shall be continuous throughout its length and shall not contain loose ends, splices or joints.

5.9 Lay**5.9.1 Direction of lay**

The direction of lay shall be Z twist (right hand lay), their strands S twist and their roping yarns Z twist.

5.9.2 Length of lay

The maximum lay of the rope shall be as given in Table 1, measured with the rope under a specified tension.

5.10 Other Characteristics

Other characteristics, for example the diameter of the circumscribed circle and the elongation of the rope under specific tensile conditions, may be specified, subject to agreement between the manufacturer and the Purchaser, where applicable with submission of a sample.

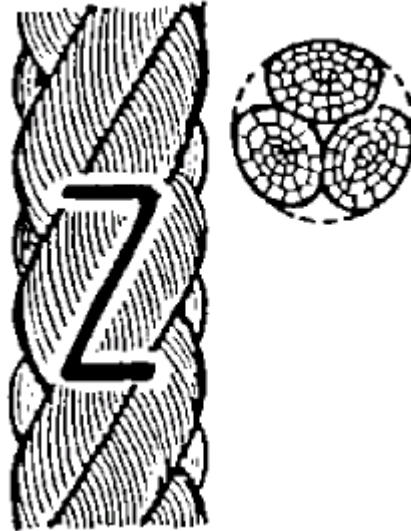

3-STRAND (PLAIN OR HAWSER LAID) 'Z' OR RIGHT-HAND LAY ROPE

Fig. 1

TABLE 1 - REQUIREMENTS FOR POLYPROPYLENE ROPE

CHARACTERISTIC	UNIT	REQUIREMENT	TEST METHOD
Nominal diameter	mm	8	ISO 2307
Linear density	ktex	30	ISO 2307
Rope lay (max.)	mm	28	ISO 2307
Breaking force (min.)	daN	1040	ISO 2307
Color		Brown	---

Notes:

1) The linear density (in kilotex) corresponds to the net mass per meter (in grams per meter) or to the mass of rope (in kilograms) per thousand meters. The linear density (net mass per meter) is measured under tensile loading given in ISO 2307.

2) The SI unit for force is the newton. A load of 1 kg \approx 1 decanewton (daN) or 0.01 kilonewton (kN).

6. QUALITY ASSURANCE PROVISIONS

6.1 It is the responsibility of the manufacturer to establish quality assurance by quality control

procedures which shall ensure that the product will meet the requirements of this Part of Standard specification.

6.2 The quality control at the manufacturing plant shall include control systems on the following:

- Raw materials, i.e. checking of documentation and/or testing for conformity with the Specification.
- Production equipment and process.
- Testing during and after production.
- Identification of ropes.
- Weight and dimension tolerances.
- Documentation (material certificates).

7. INSPECTION AND TESTING

7.1 The manufacturer is responsible for the performance of all inspection and tests required by this Part of Standard specification using his own or other reliable facilities and he shall maintain complete records of all such tests and inspections. Such records shall be available for review by the Purchaser.

7.2 All tests and inspections shall be made at the place of manufacture. The manufacturer shall afford the inspector representing the Purchaser all reasonable facilities to satisfy him that the rope has been manufactured in accordance with the requirements of this Part of Standard specification. Such inspections in no way relieve the manufacturer of his responsibilities under the terms of this Part of Standard specification.

7.3 Conformance of the rope to the requirements of this Part of Standard specification shall be determined on samples taken from each lot (see Note) of rope presented for acceptance. Unless otherwise agreed with the Purchaser, it shall be carried out at the manufacturer's factory prior to despatch, and the testing equipment shall be under the immediate direction of the Purchaser or his representative during the tests. The manufacturer shall prepare all the necessary test samples and provide the machinery, apparatus and labour required for the purpose.

Note:

Unless otherwise specified by the Purchaser, a lot shall consist of all ropes made from the same production run offered for acceptance.

7.4 Sampling shall be in accordance with the requirements of ISO 2307.

8. CERTIFICATION

8.1 The manufacturer shall provide the Purchaser with a certification stating that the ropes meet the specified requirements of this Part of Standard specification.

8.2 The test reports shall contain results of tests required by this Part of Standard specification and other tests specified by the Purchaser.

8.3 Each test report shall be signed by an authorized agent of the seller and/or manufacturer.

8.4 Certified test reports furnished by the manufacturer shall be properly identified with each lot (batch) of products.

9. PACKAGING AND DELIVERED LENGTH

9.1 Packaging

All ropes shall be coiled and protected to prevent damage in transit and storage. Coil lashings shall be of similar material to the rope. When the ropes are invoiced by gross mass, excluding packaging, the mass of the packaging shall not exceed 1.5% of the gross mass of the ropes.

9.2 Delivered Length

9.2.1 Standard delivered length

The standard delivered length shall be the length measured at zero tension. The delivered lengths, as will be specified by the Purchaser, shall be 100, 200 and 220 m.

9.2.2 Shorter delivered length due to sampling

To carry out tests at the request of the Purchaser, test pieces may be taken from the ordered length of rope. The length of rope delivered will then be less than the ordered length because of these test pieces (which are considered to be part of the delivery).

10. MARKING

The identification of the material, quality and origin of a polypropylene rope conforming to this Part of Standard specification shall be marked using a yarn or tape yarn, as defined below, of an easily identifiable brown color placed within the article so as to remain recognizable despite soiling, soaking and discoloration during use.

Tape yarn: a straight continuous strip, of thickness which is small compared with its width, obtained by cutting a film or by direct extrusion of man-made textile materials.

Note:

This brown yarn or tape yarn, marked with required information concerning the rope, shall be incorporated into a strand.

11. LABELING

Each coil shall have a label, which is firmly fixed in place, giving the following information:

- Name: Polypropylene rope.....
- Specification: [IPS-M-TP-750](#): Part 10.....
- Order No.:
- M.E.S.C No.:
- Rope size:
- Quantity: m
- Maximum temperature resistance:
- Batch No.:
- Stock No.:
- Date of manufacture:
- Storage condition:
- Manufacturer's name and address:.....

PART 11**SPLICING KIT**

CONTENTS :	PAGE No.
1. SCOPE	154
2. REFERENCES	154
3. DEFINITIONS AND TERMINOLOGY	155
4. UNITS	156
5. TECHNICAL DOCUMENTS	156
6. DESCRIPTION	157
7. REQUIREMENTS	157
8. PACKAGING	159
9. SAMPLING	159
10. REJECTION	159
11. INSPECTION AND TESTING	159
12. CERTIFICATION	160
13. LABELING	160
 APPENDICES:	
APPENDIX A_DATA SHEET_FOR SPLICING KIT	162

1. SCOPE

This Part of [IPS-M-TP-750](#) covers the minimum requirements for materials supplied in kits for making cable joints, in the voltage range up to 1000 V d.c., for use in coating of buried or submerged electrical connections in cathodic protection systems.

Note:

This Part of [IPS-M-TP-750](#) shall preferably be in conjunction with Part 12. However due to variation in numbers, size and type of conductors, connector fittings are normally supplied as separate items.

2. REFERENCES

Throughout this Standard the following dated and undated standards/codes are referred to. These referenced documents shall, to the extent specified herein, form a part of this standard. For dated references, the edition cited applies. The applicability of changes in dated references that occur after the cited date shall be mutually agreed upon by the Company and the Vendor. For undated references, the latest edition of the referenced documents (including any supplements and amendments) applies.

ANSI (AMERICAN NATIONAL STANDARDS INSTITUTE)

Z 129.1 "Precautionary Labeling of Hazardous Industrial Chemicals"

ASTM (AMERICAN SOCIETY FOR TESTING AND MATERIALS)

D 149 Standard test method for
"Dielectric Breakdown Voltage and Dielectric Strength of Solid Electrical Insulating Materials at Commercial Power Frequencies"

D 257 Standard test method for "d.c. Resistance or Conductance of Insulating Materials"

D 3892 Standard practice for "Packaging/Packing of Plastics"

D 3951 Standard practice for "Commercial Packaging"

DIN (DEUTSCHE INSTITUT FÜR NORMUNG), (GERMAN STANDARDS)

16945 "Testing of Resins, Hardeners and Accelerators, and Catalyzed Resins"

53489 "Testing of Electrical Insulating Materials; Assessing the Effect of Electrolytic Corrosion"

53505 "Testing of Rubber, Elastomers and Plastics; Shore Hardness Testing A and D"

ISO (INTERNATIONAL ORGANIZATION FOR STANDARDIZATION)

ISO 62 "Plastics-Determination of Water Absorption"

ISO 2592 "Petroleum Products-Determination of Flash and Fire Points-Cleveland Open Cup Method"

ISO 2859 "Sampling Procedures for Inspection by Attributes
Part 1: Sampling Plans Indexed by Acceptable Quality Level (AQL) for Lot-By-Lot Inspection"

VDE (DEUTSCHE ELEKTROTECHNISCHE KOMMISSION)

0291

"Compounds for Use in Cable Accessories; Casting Resinous Compounds Before (Part 2) Cure and in the Cured State"

3. DEFINITIONS AND TERMINOLOGY

For the Purposes of Part 11 of this Standard specification the following definitions apply:

Catalyzed resins (cold pour resin compound)

A resin system capable of being poured at ambient temperature and that cures to a solid state by an irreversible chemical reaction without the application of external heat.

Cured casting resins

The cured casting resins are materials produced by curing catalyzed resins (cold pour resin compound) to form moulded parts by casting in moulds.

Curing time

The curing time is the time between the exposure of the resin to the curing conditions (i.e. after the resin components have been mixed) and the time from which the mean value of the temperature of deflection does not increase by more than 3 k.

Epoxy resin

A synthetic resin containing a sufficient number of epoxide groups capable of crosslinking, and in which the final polymer is formed as a result of a reaction taking place substantially at the epoxide groups.

Gel time

The period required for a cold pour resin to reach a level of cure as defined by a specified test.

Hardeners and accelerators

Hardeners are substances or mixtures of substances which promote polymerization or polyaddition which cause the resins to cure.

Accelerators are substances which are used in small amounts to increase the reaction rate of a chemical system (e.g. crosslinking).

Hardness

The resistance to indentation as measured under specified conditions.

Lot or batch

The lot or batch shall consist of an indefinite number of splicing kits (catalyzed resins, cast mold, etc.) manufactured by a single plant run through the same processing equipment with no change in ingredient materials, offered for acceptance.

Nominal parameters

The nominal parameters are the parameters (e.g., weight, dimensions, density, etc.) specified on product labels, invoices, sales literature, and the like. The actual parameters shall not be less than 95% of nominal parameters.

Polyurethane resin

A synthetic resin produced by the reaction of a polyhydroxy reactant, normally of polyester or polyether structure, with a poly-isocyanate.

Pot life

The period from commencement of adding the reactive agents of the cold pour resin compound during which it may be poured without affecting its performance.

Resins

For the purpose of this Standard, a resin is a liquid or liquefiable organic material that cures as a result of polyaddition without releasing volatile components, with or without agents such as accelerators or hardeners being added.

Shelf life

The period of time after production during which a material or product that is stored under specified conditions retains its intended performance capabilities.

Total volume shrinkage

The volume shrinkage is the shrinkage during curing and the shrinkage on cooling the cured material from the curing temperature to ambient temperature.

The total volume shrinkage calculated from the density of the resin at curing temperature and the density of the cured material at 23°C.

For cold curing systems, the total volume shrinkage calculated from the density of the resin at 23°C and that of the cured material at 23°C.

Volume resistivity

The ratio of the electric potential gradient to the current density when the gradient is parallel to the current in the material.

Water absorption

The amount of water absorbed by a material under specified test conditions.

4. UNITS

This Standard is based on International System of Units (SI), except where otherwise specified.

5. TECHNICAL DOCUMENTS

The technical bid shall include the following:

- catalogue showing materials, maximum voltage, dimensions and configuration;
- material specification for the components to be offered (complete kit);

- manufacturing specification and procedure;
- inspection and testing specification and procedure;
- installation instructions that are specific to the joint;
- the contents;
- the name of the manufacturer and the reference number;
- instructions on how to use the resin compound in the manner necessary to develop the properties and to reach the level of performance specified in this Part of [IPS-M-TP-750](#);
- instructions on how to keep the resin compound before use in conditions that will comply with any relevant regulations and that will ensure that the resin compound retains its properties for two years (see 7.2.4);
- specification of packaging.

6. DESCRIPTION

6.1 General

Each splicing kit shall contain the following components:

- Two-piece snap-together plastic mold.
- Two-pack catalyzed resins (resin and hardner).
- Funnel/funnel cap.
- Proper electrical insulating and sealing tapes.

6.2 Types

The splicing kits, as will be specified by the Purchaser (see data sheet), shall be one of the following types:

- | | |
|------------------------------------|--|
| "Branch" type: | Intended for use in shallow type groundbeds. |
| "Straight-through" (in-line) type: | Intended for use in deep-well type groundbeds. |

7. REQUIREMENTS

7.1 Materials and Manufacture

7.1.1 Cast mold

The two-piece snap-together mold shall be made of synthetic thermoplastic material (i.e. polycarbonate), cast into a desired shape designed to provide a transparent, self sealing, water proof and high strength product. The mold size shall be such as to form a water resistant seal over the connection giving a voltage rating of 600/1000 Volts. It shall withstand the weight and exotherm of the compound without undue distortion, such that when supported in accordance with the manufacturer's instructions the design clearances are maintained during setting.

Cast molds shall be provided with filling apertures to allow easy filling with resin compound and shall be designed such that the filling operation does not entrap air within the joint.

The molds shall be designed to permit a minimum of 10 mm thickness of cured compound over each joint component and cable component involved in the jointing procedure. The mold design shall allow the longitudinal seal on each cable sheath to be a minimum of 40 mm in length.

7.1.2 Catalyzed resins

The catalyzed resins (cold pour resin compound) shall be an unfilled two-component Epoxy (EP) or Polyurethane (PUR) resin conforming to DIN VDE 0291 Part 2, and this Part of Standard specification which, after mixing, sets quickly to form a stable, void-free resilient molded parts by casting in molds for low voltage cables rated up to 1 kV.

The base component not including curing systems shall contain no fatty acids, oils, chlorinated type plasticizers or polystyrene resins. The resin compounds shall contain no toluene diisocyanate and no aromatic substituted isocyanates.

7.2 Properties of Catalyzed Resins

The catalyzed resins shall comply with the requirements of Table 1 and 7.2.1 to 7.2.4 inclusive.

7.2.1 Odor

The odor of the admixed cast resin, wet or dry, shall not be obnoxious.

7.2.2 Working properties

The cold pour resin compound shall be fresh and show no signs of partial cure from having been improperly stored. Neither shall it possess other detectable defects which adversely affect the ultimate performance of the material.

The fully cured casting resins shall not be attacked by oils, petrols, water, salt and salt solution.

7.2.3 Toxicity

The manufacturer shall certify that the materials shall have no adverse effect on the health of personnel when used (mixed, applied, and cured).

7.2.4 Shelf life

The two-pack catalyzed resins when stored in the original container at ambient temperature, between 10 - 45°C, shall have a minimum shelf life of 24 months from the date of delivery and shall meet all the requirements specified herein. After such storage, the catalyzed resins shall show no instability, hardening of the resin components, settling out of the pigment, and deterioration of the two-compartment plastic mixing bag.

7.3 Dimensions

For specified cables and connectors to be joined (see attached data sheet), the dimensions of mold and required quantity of resin compound shall be submitted by the supplier.

TABLE 1 - PROPERTIES OF CATALYZED RESINS (COLD POUR COMPOUND)

PROPERTY	UNIT	REQUIREMENT	TEST METHOD
Cast resin component	°C	> 100	ISO 2592
Open cup flash point (min.)	°C	> 55	ISO 2592
Reactant			
Open cup flash point (min.)			
Gel time; at 23°C (max.)	Minutes	30	DIN 16945
Total volume shrinkage (max.)	%	4	DIN 16945
Hardness (min.)	Shore D	70	DIN 53505
Water absorption (max.)	mg	25	ISO 62
In cold water after 24 h at 23°C			
Electrolytic corrosion (at least)	Grade	A 1.2	DIN 53489
Dielectric strength (min.)			
1 minute test voltage; at 23°C	kV	10	ASTM D 149
		10	
Volume resistivity (min.) at 23°C	Ohm. cm	1×10^{12}	ASTM D 257

8. PACKAGING

8.1 Packaging shall be sufficient to ensure that deterioration of the components will not happen under covered, dry storage within the stated ambient air temperatures such that the performances of these components when forming part of the total joint are unaffected.

8.2 The splicing kits shall be packaged, in cardboard boxes, in accordance with the best commercial practice.

8.3 The resin and hardener components shall be packed in exact doses in a two-chamber transparent plastic bag, with aluminum resistive layer, sealed against air and damp. The complete package shall be designed to ensure the item against damage during shipment, handling and storage. The packaging/packing shall also meet the relevant requirements of ASTM Standard Practice D 3951 and D 3892.

8.4 All shipments shall be marked "store in cool place out of direct sunlight".

9. SAMPLING

Sample splicing kits shall be selected from each lot in accordance with inspection Level II of ISO 2859 (Part 1). The acceptable quality level shall be 4 percent for all visual, dimensional and weight defects combined and 2.5 percent for all other type of defects with reference to this Part of Standard specification. The single sampling plans for normal inspection (Table II A of ISO 2859 Part 1) shall be used.

10. REJECTION

Where the numbers of splicing kits that do not conform to this Part of Standard specification exceed the acceptance numbers specified in 9, this shall be cause for rejection of entire lot.

11. INSPECTION AND TESTING

11.1 The manufacturer and/or supplier shall be responsible for carrying out all the tests and inspections required by this Part of Standard specification, using his own or other reliable facilities, and he shall maintain complete records of all such tests and inspections. Such records shall be available for review by the Purchaser.

11.2 The manufacturer and/or supplier shall afford the Purchaser's inspector all reasonable facilities necessary to satisfy him that the product is being produced and furnished in accordance with this Part of Standard specification. Such inspections in no way relieve the manufacturer and/or supplier of his responsibilities under the terms of this Part of Standard specification.

11.3 The Purchaser reserves the right to perform any inspections set forth in this Part of Standard specification where such inspections are deemed necessary to assure that supplies and services conform to the prescribed requirements.

11.4 The purchaser's inspector(s) shall have access to the material subject to inspection for the purpose of witnessing the selection of the samples, the preparation of the test samples, and the performance of the tests.

11.5 Samples of any or all ingredients used in the manufacture of this material may be requested by the Purchaser and shall be supplied upon request, along with the supplier's name and identification for the sample.

12. CERTIFICATION

12.1 The manufacturer shall provide the Purchaser with a certification stating that the splicing kits meet the specified requirements of this Part of Standard specification.

12.2 The test reports shall contain results of tests required by this Part of Standard specification and other tests specified by the Purchaser.

12.3 Each test report shall be signed by an authorized agent of the seller and/or manufacturer.

12.4 Certified test reports furnished by the manufacturer shall be properly identified with each lot (batch) of products.

13. LABELING

13.1 Refer to ANSI Standard Z 129.1 "Precautionary Labeling of Hazardous Industrial Chemicals".

13.2 Each cast mold shall be plainly marked with the following information:

- a) The name and/or trademark of the manufacturer.
- b) The type and tradename of material.
- c) The size.

13.3 Each catalyzed resins-bag shall be legibly marked with the following information:

- a) The name and/or trademark of the manufacturer.
- b) The type and trade name of material.
- c) The size.
- d) The quantity (in both g and ml).
- e) The batch No.
- f) The data of manufacture.
- g) The pot life.
- h) The shelf life.
- i) The flash point.
- j) The direction for use (mixing instruction).
- k) The direction for safety.
- l) The cleaning material.
- m) The cautions.

13.4 Each kit box shall be marked with the following information:

- Name : Splicing kit
- Specification: [IPS-M-TP-750](#): Part 11.....
- Order No.:
- M.E.S.C No.:
- Type and trade name of material:
- Dimensions of mold:
- Quantity of catalyzed resins (in both g and ml):
- Max. temperature resistance:
- Application temperture :
- Storage condition:

- Batch No.:
- Stock No.:
- Date of manufacture:
- Shelf life (min.):
- Contents of kit box:.....
- Information and warnings (if needed):
- Manufacturer's name and address:.....

13.5 Direction for Use

The manufacturer shall supply complete instructions covering uses, preparation, mixing (of catalyzed resins), resin pressure method, pouring method, application method, application conditions, pot life, temperature and humidity limitation, drying time, etc., with each kit box.

13.6 Health and Safety

The manufacturer shall make available to the Purchaser such information concerning the cold pour resin compound as will enable the Purchaser and his employees:

- a) To be aware of the recommended immediate action in the case of the compounds coming in contact with skin, eyes or clothing;
- b) to transport the compound outside the Purchaser's premises in a manner complying with any regulations relevant to the mode of transport to be used.

The manufacturer shall ensure that all the packages in which the compounds are supplied and the information given on these packages comply with the Classification, Packaging and Labeling of Dangerous Substances Regulations 1984, where applicable.

The manufacturer shall also make available such information as will enable the Purchaser to use the compound in a safe manner in accordance with the Health and Safety at Work, etc.

APPENDICES

APPENDIX A
DATA SHEET

(TO BE SUBMITTED BY THE PURCHASER)

FOR

IPS-M-TP-750: Part 11

SPLICING KIT

Cable splicing kit, for use in coating of buried or submerged electrical connections in cathodic protection systems.

The kits shall be in accordance with the latest edition of above Iranian Petroleum Standard with the following specific requirements:

- Project title:
 - Indent No.:
 - M.E.S.C No.:
 - Mold type : b "Branch" type
 - Main (feeder) cable type & size:
 - Branch cable type & size:
 - Cable connector type & size:
 - Quantity:
- Date:
 - Purchaser:
 - b "In Line" type

PART 12**SPLIT BOLT CONNECTOR (LINE TAP)**

CONTENTS :	PAGE No.
1. SCOPE	165
2. REFERENCES	165
3. UNITS	165
4. TECHNICAL DOCUMENTS	165
5. REQUIREMENTS	165
6. QUALITY ASSURANCE PROVISIONS	167
7. PACKAGING	167
8. LABELING	168
 APPENDICES:	
APPENDIX A DATA SHEET FOR SPLIT BOLT CONNECTOR (LINE TAP)	169

1. SCOPE

This Part of [IPS-M-TP-750](#) covers the minimum requirements for mechanical split bolt connector (line tap) for use in making, through or tap, connections of stranded copper conductors, 600/1000 Volts rating, in cathodic protection installations.

2. REFERENCES

Throughout this Standard the following dated and undated standards/codes are referred to. These referenced documents shall, to the extent specified herein, form a part of this standard. For dated references, the edition cited applies. The applicability of changes in dated references that occur after the cited date shall be mutually agreed upon by the Company and the Vendor. For undated references, the latest edition of the referenced documents (including any supplements and amendments) applies.

ANSI (AMERICAN NATIONAL STANDARDS INSTITUTE)

ANSI/UL * 486 A	"Wire Connectors and Soldering Lugs for Use With Copper Conductors"
-----------------	---

BSI (BRITISH STANDARDS INSTITUTION)

BS 1872	"Electroplated Coatings of Tin"
---------	---------------------------------

3. UNITS

This Standard is based on International System of Units (SI), except where otherwise specified.

4. TECHNICAL DOCUMENTS

The technical bid shall include the following:

- a) Catalogue (including technical data of the offered connector).
- b) Production procedures that cover all stages of the manufacturing process, from receipt of raw materials to finishing and packing for shipment, including:
 - Chemical analysis.
 - Material specification.
 - Measurements of weight, dimensions, etc.
 - Inspection and testing procedures, including acceptance criteria, and frequencies.
 - Line tap manufacture.
 - Specification of packaging.

5. REQUIREMENTS

5.1 General Requirements

The split bolt connectors (line taps) shall be manufactured, inspected and tested in accordance with ANSI/UL Standard 486 A and this Part of Standard specification.

* **Underwriters Laboratories Inc.**

5.2 Materials and Manufacture

5.2.1 The split bolt connectors as cast shall be manufactured from copper-zinc-lead alloy (leaded-brass), having a chemical composition conforming to requirements specified in Table 1, tinned all over by electroplating to BS 1872 with the minimum thickness of 5 µm.

The materials shall be of such quality and purity that the finished product have the properties and characteristics prescribed herein.

5.2.2 The bolt threads shall be of sufficient strength to withstand the tightening required to produce a zero resistance connection.

TABLE 1 - CHEMICAL REQUIREMENTS

ELEMENT	COMPOSITION, %
Copper	55 - 60
Lead	2.0 - 3.8
Iron, max.	0.35
Zinc	Remainder

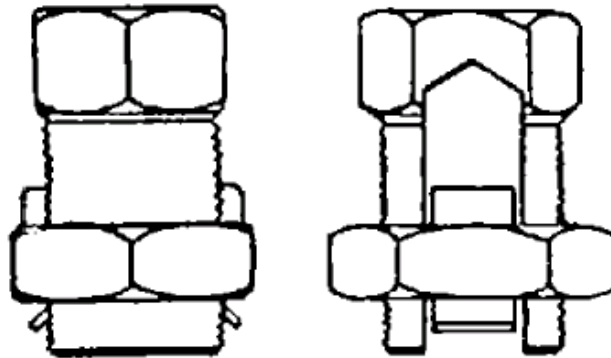

SPLIT BOLT CONNECTOR (LINE TAP)

Fig. 1

5.3 Dimensions

The split bolt connectors shall be of such dimensions as to be capable of joining the specified number of cables of specified dimensions (see data sheet) and shall be suitable for fittings into the splicing kit ([IPS-M-TP-750](#): Part 11). The supplier shall submit to the Purchaser, the dimensions and contours, including dimensional tolerances of offered connectors, preferably by a drawing.

5.4 Workmanship, Finish, and Appearance

The split bolt connectors shall have a workmanlike finish free of injurious burrs, seams, laps, irregular surfaces, and other imperfections affecting serviceability.

6. QUALITY ASSURANCE PROVISIONS

6.1 General

6.1.1 It is the responsibility of the manufacturer to establish quality assurance by quality control procedures which shall ensure that the product will meet the requirements of this Part of Standard specification.

6.1.2 The quality control at the manufacturing plant shall include control systems on the following:

- Raw materials, i.e. checking of documentation.
- Production equipment and process.
- Testing during and after production.
- Identification of line taps.
- Chemical analysis.
- weight and dimensional tolerances.
- Surface condition of produced line taps.
- Documentation (material certificates).

6.2 Responsibility for Inspection

6.2.1 The manufacturer is responsible for the performance of all inspection and test requirements specified. Except as otherwise specified in the contract or purchase order, the manufacturer may use his own or any other suitable facilities for the performance of the inspection and test requirements unless disapproved by the Purchaser at the time the order is placed. The Purchaser shall have the right to perform any of the inspections and tests set forth in this Part of Standard specification when such inspections and tests are deemed necessary to assure that the material conforms to the prescribed requirements.

6.2.2 When specified on the inquiry or purchase order, the product shall be subject to inspection by the Purchaser at the place of manufacture prior to shipment. The inspector representing the Purchaser shall have controlled entry only to those parts of the manufacturer's operations that concern the manufacture of the ordered product and only when and where work on the contract of the Purchaser is being performed. The manufacturer shall afford the inspector all reasonable facilities to satisfy him that the product is being furnished in accordance with this Part of Standard specification.

6.3 Test Reports

The manufacturer and/or supplier shall furnish to the Purchaser a manufacturer's test report showing the results of the required tests.

6.4 Certification

A manufacturer's certificate of compliance shall be furnished to the Purchaser stating that each lot has been sampled, tested, and inspected in accordance with this Part of Standard specification and the requirements have been met.

7. PACKAGING

The materials purchased according to this Part of Standard specification shall be preserved and packaged for shipment in such a manner as to ensure acceptance by common carrier for

transportation and to afford protection from the normal hazards of transportation.
Each package of materials shall contain cleaning and tightening instructions.

8. LABELING

8.1 Identification Marking

The split bolt connectors shall be plainly marked for identification with the following information:

- a) Manufacturer's name or trade mark;
- b) a distinctive catalog number;
- c) wire-size or range of sizes.

8.2 Package Marking

Each shipping unit shall be legibly marked with the following information:

- Name: Split bolt connector (line tap)
- Specification: [IPS-M-TP-750](#): Part 12.....
- Order No.:
- M.E.S.C No.:
- Catalog or type designation:
- Size:
- Weight (gross and net):
- Batch No.:
- Stock No.:
- Date of manufacture:
- Quantity:
- Trademark of the supplier:
- Manufacturer's name and address:.....

APPENDICES**APPENDIX A
DATA SHEET****(TO BE SUBMITTED BY THE PURCHASER)****FOR****IPS-M-TP-750: Part 12 **SPLIT BOLT CONNECTOR (LINE TAP)****

The connectors shall be in accordance with the latest edition of above Iranian Petroleum Standard with the following specific requirements:

- Project title:
- Indent No.:
- M.E.S.C No.:
- Main (feeder) cable type and size:
- Branch (anode) cable type and size:
- Quantity:
- Date:
- Purchaser:

PART 13**SPLICE COATING MATERIALS**

CONTENTS :

PAGE No.

1. SCOPE	172
2. REFERENCES	172
3. UNITS	172
4. ELECTRICAL INSULATING PLASTIC TAPE	172
5. RUBBER SPLICING TAPE	174
6. STORAGE LIFE, PACKAGING, AND SAMPLING	175
7. INSPECTION AND TESTING	176
8. CERTIFICATION	176
9. LABELING	176

1. SCOPE

This Part of [IPS-M-TP-750](#) covers the minimum requirements for the following coating materials as electrical insulation for use on joints and splices in wires and cables in accordance with the National Electrical Code.

- a) Electrical insulating plastic tape.
- b) Rubber splicing tape.

2. REFERENCES

Throughout this Standard the following dated and undated standards/codes are referred to. These referenced documents shall, to the extent specified herein, form a part of this standard. For dated references, the edition cited applies. The applicability of changes in dated references that occur after the cited date shall be mutually agreed upon by the Company and the Vendor. For undated references, the latest edition of the referenced documents (including any supplements and amendments) applies.

ASTM(AMERICAN SOCIETY FOR TESTING AND MATERIALS)

D 1000	Standard methods of testing for "Pressure-Sensitive Adhesive Coated Tapes Used for Electrical Insulation"
D 297	Standard methods of "Chemical analysis of Rubber Products"
D 119	Standard specification for "Low Voltage Rubber Insulating Tape"

3. UNITS

This Standard is based on International System of Units (SI), except where otherwise specified.

4. ELECTRICAL INSULATING PLASTIC TAPE

4.1 Materials and Manufacturer

The tape shall consist of a plastic backing coated on one side with a pressure-sensitive adhesive.

The backing shall be either PVC (Polyvinyl Chloride or copolymer of vinyl chloride and vinyl acetate), or PE (thermoplastic polyethylene) suitably compounded to meet the requirements of this Part of Standard specification. The backing shall be smooth and uniform. The tape edges shall be straight and unbroken.

The pressure sensitive adhesive layer shall be smooth and uniform and as free from lumps and bare spots as the best commercial practice will permit. "Fish Eyes" shall not be cause for rejection. There shall be no adhesive transfer when the tape is unwound from the roll.

The tape shall provide high electrical resistivity, resistance to corrosive environments, low moisture absorption and permeability, and shall form water-tight bond with itself and with rubber tape.

4.2 Requirements

4.2.1 A thermoplastic insulating tape conforming to this Part of Standard specification shall meet the requirements listed in Table 1 and 4.2.2 to 4.2.6 inclusive.

4.2.2 Deformation test

4.2.2.1 The thickness of the insulation on a splice covered with PE tape shall not decrease more than 40 percent when conditioned, under pressure, in a full-draft circulating-air oven operating at a temperature of $100.0 \pm 1.0^{\circ}\text{C}$ as described in paragraph 4.2.2.2 and the corresponding decrease in thickness shall not be more than 65 percent for PVC tape.

4.2.2.2 A bare 3.3 mm^2 (No. 12 AWG) solid copper conductor is to be wrapped with successive layers of tape, with each layer of tape directly over the one below, until a thickness of tape equal to approximately 0.8 mm is in place over the conductor. The thickness of the insulation (tape) is to be measured by means of a dead-weight dial micrometer having no added weight and a presser foot $9.5 \pm 0.2 \text{ mm}$ in diameter. The specimen is then to be placed in the oven for 1 h of preliminary heating at a temperature of $100.0 \pm 1.0^{\circ}\text{C}$ along with the dial micrometer and a weight to cause the foot of the micrometer to press on a specimen placed between the foot and the anvil with 500 gf or 4.90 N. At the end of 1 h, the specimen is to be placed under the foot of the dial micrometer with the weight added and then is to remain in the oven with the oven operating at full-draft at a temperature of $100.0 \pm 1.0^{\circ}\text{C}$ for an additional hour. At the end of the second hour, the dial of the micrometer is to be read, without removing the specimen or the dial micrometer from the oven, and the percent decrease in the thickness of the insulation (tape) is to be calculated.

4.2.3 Storage test

4.2.3.1 A thermoplastic insulating tape shall retain its adhesive qualities so as to be capable of being used to insulate splices when an unused roll of tape is conditioned in a full-draft circulating-air oven operating at a temperature of $40.0 \pm 1.0^{\circ}\text{C}$ for 60 days or, at the manufacturer's option, a temperature of $65.0 \pm 1.0^{\circ}\text{C}$ for 240 h (10 days).

4.2.3.2 To determine whether a thermoplastic tape complies with the requirements in paragraph 4.2.3.1, an unused roll of tape, in its original container, is to be laid flat in a full-draft circulating-air oven operating at the temperature and for the time indicated in paragraph 4.2.3.1, after which the tape is to comply with the requirements in Table 13.1 for adhesion strength.

4.2.4 Test for indirect measurement of conductor corrosion

4.2.4.1 PVC tape shall exhibit a resistance of 1.0 teraohm (1,000,000 megohms) or more for a 25 mm width of tape when five specimens are tested in accordance with the ASTM D 1000 82a, using copper electrodes. The conditioning temperature of specimens with the copper electrodes shall be $23.0 \pm 1.0^{\circ}\text{C}$.

4.2.5 Roll size

The roll size shall be as follows:

Roll length : 20 m.

Roll width : 19 mm.

4.2.6 Color

The color of plastic backing shall be black.

TABLE 1 - REQUIREMENTS FOR ELECTRICAL INSULATING PLASTIC TAPE

PROPERTY	UNIT	REQUIREMENT	TEST METHOD ASTM
Thickness (avg.)	mm	0.02 ±0.02	D 1000
Breaking strength (min.)	kN/m	2.6	D 1000
Elongation (min.)	%	150	D 1000
Dielectric breakdown (min.)	kV/mm		
Standard condition		40	D 1000
wet condition (96/23/96) ¹⁾		90% of dry	
Adhesion strength (min.) to Steel	N/mm	0.175	D 1000 (Method A)
Backing		0.175	
Backing at -7°C		0.175	
Unwind at -7°C			
Minimum	N/m	175	D 1000 (Method B)
Maximum		1400	
Static elongation at -7°C (min.)	%	15	D 1000
High-humidity insulation resistance (min.)	MΩ median	1 × 10 ⁵	D 1000

¹⁾ Conditioning for 96 hours in air at 23.0 ±1.0°C and 96 ±2 percent relative humidity.

5. RUBBER SPLICING TAPE

5.1 Materials and Manufacture

5.1.1 A rubber splicing tape shall consist of a compound of unvulcanized or partially unvulcanized natural or synthetic rubber, or a blend thereof (Ethylene-propylene copolymer or ethylene-propylene terpolymer), that shall contain not more than 0.5 percent of free sulphur by weight of the original compound when tested in accordance with the ASTM D 297. The tape shall be smooth and uniform. The tape edges shall be straight and unbroken.

5.1.2 A separator of parchment paper, glazed sheeting, polyester film, or similar material shall be interposed between adjacent layers of a roll of tape and shall cover the outside of the tape.

5.2 Requirements

5.2.1 A rubber splicing tape conforming to this Part of Standard specification shall meet the requirements listed in Table 2 and 5.2.2 to 5.2.5 inclusive.

5.2.2 Sticking and unraveling tendency

When a roll of tape is originally unwound, the separator shall not show undue tendency to stick or to unravel.

5.2.3 Storage test

5.2.3.1 A rubber splicing tape shall retain its adhesive qualities so as to be capable of being used to insulate splices when an unused roll of tape is conditioned in a full-draft circulating-air oven at a temperature of 40.0 ±1.0°C for 60 days (1440 h).

5.2.3.2 To determine whether a rubber tape complies with the requirements in paragraph 5.2.3.1, an unused roll of tape, in its original container, is to be laid flat in a full-draft circulating-air oven

operating at a temperature of 40.0 ±1.0°C for 60 days (1440 h). After this conditioning, the tape is not to become unduly attached to the separator and is to meet the fusion test in the ANSI/ASTM D 119.

5.2.4 Roll size

The roll size shall be as follows:

Roll length : 9 m.

Roll width : 19 mm.

5.2.5 Color

The tape color shall be black.

TABLE 2 - REQUIREMENTS FOR RUBBER SPLICING TAPE

PROPERTY	UNIT	REQUIREMENT	TEST METHOD ASTM
Thickness	mm	0.75 – 1.0	D 1000
Breaking strength (min.)	kN/m	1.4	D 1000
Elongation (min.)	%	800	D 1000
Dielectric breakdown (min.)	V/mm		
Standard condition		3.2 × 10 ⁴	D 1000
wet condition (96/23/96) ¹⁾		90% of dry	

¹⁾ Conditioning for 96 hours in air at 23.0 ±1.0°C and 96 ±2 percent relative humidity.

6. STORAGE LIFE, PACKAGING, AND SAMPLING

6.1 Storage Life

The tapes shall meet the requirements of Clauses 4.2 and 5.2 as appropriate after storage for 60 months from the date of delivery, in a tightly covered container.

6.2 Packaging

The individual rolls shall be packaged in such a manner as to protect the material against physical and mechanical damage and contamination during transit. The packaged material shall be packed in suitable containers to assure acceptance by common carrier and to provide product protection against loss and damage during multiple shipments, handling, and storage.

6.3 Sampling

6.3.1 Lot

A Lot or batch shall consist of an indefinite number of rolls, offered for acceptance, of tapes manufactured by a single plant run through the same processing equipment with no change in ingredient materials.

6.3.2 Unless otherwise specified by the Purchaser, the number of samples for testing shall consist of 10 percent of the lot, but in no case shall be less than one or more than ten rolls. The results of tests on four specimens cut from each sample roll shall be averaged for each test specified in this Part of Standard specification to determine conformance with the specified requirements.

6.3.3 The selection of rolls, sampling, conditioning and testing shall be in accordance with ASTM Test Method D 1000.

7. INSPECTION AND TESTING

7.1 The manufacturer and/or supplier shall be responsible for carrying out all the tests and inspections required by this Part of Standard specification, using his own or other reliable facilities, and he shall maintain complete records of all such tests and inspections. Such records shall be available for review by the Purchaser.

7.2 The manufacturer and/or supplier shall afford the Purchaser's inspector all reasonable facilities necessary to satisfy him that the product is being produced and furnished in accordance with this Part of Standard specification. Such inspections in no way relieve the manufacturer and/or supplier of his responsibilities under the terms of this Part of Standard specification.

7.3 The Purchaser reserves the right to perform any inspections set forth in this Part of Standard specification where such inspections are deemed necessary to assure that supplies and services conform to the prescribed requirements.

7.4 The Purchaser's inspector shall have access to the material subject to inspection for the purpose of witnessing the selection of the samples, the preparation of the test samples, and the performance of the tests.

7.5 Samples of any or all ingredients used in the manufacture of this material may be requested by the Purchaser and shall be supplied upon request, along with the supplier's name and identification for the sample.

8. CERTIFICATION

8.1 The manufacturer shall provide the Purchaser with a certification stating that the tapes meet the specified requirements of this Part of Standard specification.

8.2 The test report shall contain results of tests required by this Part of Standard specification and other tests specified by the Purchaser.

8.3 Each test report shall be signed by an authorized agent of the seller and/or manufacturer.

8.4 Certified test reports furnished by the manufacturer shall be properly identified with each lot (batch) of products.

9. LABELING

9.1 Marking of Rolls

Each roll shall be marked with the following information:

- a)** Name or trademark of the manufacturer;
- b)** type or trade name of tape;
- c)** length of the roll (in m.);
- d)** width of the roll (in mm.);
- e)** thickness of the tape (in mm.);

9.2 Marking of Containers

Each unit pack, and each package containing a number of unit packs, shall be plainly marked with

the following information:

- Name: (i.e. electrical insulating tape, or rubber tape)
- Specification: [IPS-M-TP-750](#): Part 13.....
- Order No:
- M.E.S.C No:
- Type or trade name of tape:
- Roll sizes: Length m, width..... mm, thickness mm
- Color:
- No. of rolls in the unit pack:
- Batch No.:
- Stock No.:
- Date of manufacture:
- Declared expire date (if applicable):
- Quantity (Number of rolls):
- Manufacturer's name and address:.....

"This Side Up" or a similar indication, appropriately positioned, so that the rolls of tape will be laying flat on their cut edges".

PART 14**THERMIT WELD (CAD WELD) POWDER**

CONTENTS :	PAGE No.
1. SCOPE	180
2. REFERENCES	180
3. DEFINITIONS	180
4. UNITS	180
5. TECHNICAL DOCUMENTS	180
6. GENERAL REQUIREMENTS	180
7. STORAGE LIFE	181
8. PACKAGING	181
9. SAMPLING	181
10. REJECTION	181
11. INSPECTION	181
12. CERTIFICATION	181
13. MARKING	182

1. SCOPE

This Part of [IPS-M-TP-750](#) covers the minimum requirements for the supply of thermit weld (cad weld) powder for connection of cathodic protection leads to new or in-service steel pipes, tanks, and structures by thermit welding process.

2. REFERENCES

Throughout this Standard the following dated and undated standards/codes are referred to. These referenced documents shall, to the extent specified herein, form a part of this standard. For dated references, the edition cited applies. The applicability of changes in dated references that occur after the cited date shall be mutually agreed upon by the Company and the Vendor. For undated references, the latest edition of the referenced documents (including any supplements and amendments) applies.

ISO (INTERNATIONAL ORGANIZATION FOR STANDARDIZATION)

2859-1

"Sampling Procedures for Inspection by Attributes

Part 1: Sampling Plans Indexed by Acceptable Quality Level (AQL) for Lot-by-Lot Inspection"

3. DEFINITIONS

For the purposes of this Part of Standard specification the following definitions apply:

Thermit weld powder

The thermit weld (cad weld) powder is a mixture of finely ground aluminum powder and copper oxide.

Thermit welding

Welding in which welding heat is obtained from reacting a mixture of copper oxides with aluminum powder. The ignition of which produces aluminum oxide (in the form of slag) and super-heated molten copper that flows into the weld cavity and welds the cable to the pipe.

Notes:

- 1) Mixtures described are manufactured under the trade name "Thermoweld" by the Burndy Corporation, and under the trade name "Cad weld" by Erico Products Inc.
- 2) For the purpose of this Part of Standard specification, thermit welds, thermowelds, and cad welds are synonymous.

4. UNITS

This Standard is based on International System of Units (SI), except where otherwise specified.

5. TECHNICAL DOCUMENTS

The technical bid shall include the following:

- a) Catalogue (including technical data of the offered material).
- b) Production procedures that cover all stages of the manufacturing process, from receipt of raw materials to finishing and packing for shipment, including:
 - Chemical analysis of alloy (material specification).
 - Measurements of individual cartridge weight.
 - Inspection and testing procedures, including acceptance criteria, and frequencies.
 - Preservation, packing and shipping procedures, including methods, material and any requirement for periodic inspections.

6. GENERAL REQUIREMENTS

6.1 The thermit weld powder for all welds of copper cable to steel pipe irrespective of cable size shall be cartridge No. 15 (15 grams).

6.2 Each cartridge powder charge shall be enclosed in a separate polyethylene tube containing 15

grams with starting powder at the bottom.

6.3 Individual cartridge tubes along with the required metal discs shall be tightly packaged 20 nos. to a plastic box and nos. of plastic boxes shall be tightly packaged in a cardboard package.

6.4 The material shall be of such quality and purity that when applied, produces strong and permanent high conductivity connection.

7. STORAGE LIFE

The material shall meet the initial properties after storage for at least 3 years from the date of delivery at normal storage conditions.

8. PACKAGING

The material purchased according to this Part of Standard specification, shall be packaged in suitable containers, in accordance with the best commercial practice. The complete package shall be designed to ensure the item against damage during shipment, handling and storage.

9. SAMPLING

9.1 Lot

Unless otherwise specified by the Purchaser, a lot shall consist of all thermit weld powders made from the same production run offered for inspection at one time.

9.2 Sampling for Inspection

Sample cartridge powders shall be selected from each lot in accordance with inspection level II of ISO 2859 (Part 1). The acceptable quality level shall be 2.5 percent for all visual, weight and all other type of defects with reference to this Part of Standard specification. The single sampling plans for normal inspection (Table II A of ISO 2859 (Part 1)) shall be used.

10. REJECTION

Where the numbers of thermit weld powders that do not conform to this Part of Standard specification exceed the acceptance numbers specified in 9.2, this shall be cause for rejection of entire lot.

11. INSPECTION

11.1 The manufacturer and/or supplier shall be responsible for carrying out all the tests and inspections required by this Part of Standard specification, using his own or other reliable facilities, and he shall maintain complete records of all such tests and inspections. Such records shall be available for review by the Purchaser.

11.2 The supplier shall provide to Purchaser the following details as supported by actual test results:

- Weight of individual cartridges in grams.
- Analysis of alloy.

11.3 The manufacturer and/or supplier shall afford the Purchaser's inspector all reasonable facilities necessary to satisfy him that the material is being produced and furnished in accordance with this Part of Standard specification. Such inspections in no way relieve the manufacturer and/or supplier of his responsibilities under the terms of this Standard specification.

11.4 The Purchaser shall have the right to perform any of the inspections and tests set forth in this Part of Standard specification when such inspections and tests are deemed necessary to assure that the material conforms to the prescribed requirements.

12. CERTIFICATION

12.1 The manufacturer shall provide the Purchaser with a certification stating that the thermit weld powders meet the specified requirements of this Part of Standard specification.

12.2 The test report shall contain results of tests required by this Part of Standard specification and other tests specified by the Purchaser.

12.3 Each test report shall be signed by an authorized agent of the seller and/or manufacturer.

12.4 Certified test reports furnished by the manufacturer shall be properly identified with each lot (batch) of products.

13. MARKING

13.1 For the purpose of marking requirements, containers are defined as follows:

a) Unit container

The smallest container in which cartridge powders are packaged.

b) Packaging container

The container in which the unit containers are packaged.

13.2 Each unit container shall be marked with the following information:

- Type or trade name of material.
- Manufacturer's name.
- Distinctive catalog number.
- Size designation.
- Quantity (per box).
- Minimum shelf life.

13.3 Each packaging container shall be plainly marked with the following information:

- Name: Thermit weld (cad weld) powder
- Specification: [IPS-M-TP-750](#): Part 14.....
- Order No:
- M.E.S.C No:
- Type or trade name of material:
- Catalog No.:
- Size:
- Maximum temperature resistance (°C):
- Batch No.:
- Stock No.:
- Date of manufacture:
- Quantity (of material in container):
- Minimum shelf life:
- Storage conditions:
- Name or trademark of the supplier:
- Manufacturer's name and address:.....

13.4 Each unit container shall contain instruction for use.